

Y:\Engineering\09 Engineering Staff\Johnathan McGurn\Sample Hoist Zone Approvals\Ultralite Telescoping Gantry Crane\GCU_Customer.dwg
 Last Saved: 03-06-2025 @ 09:33:35 JOHN MCGURN (Sample Hoist Zone Approvals)

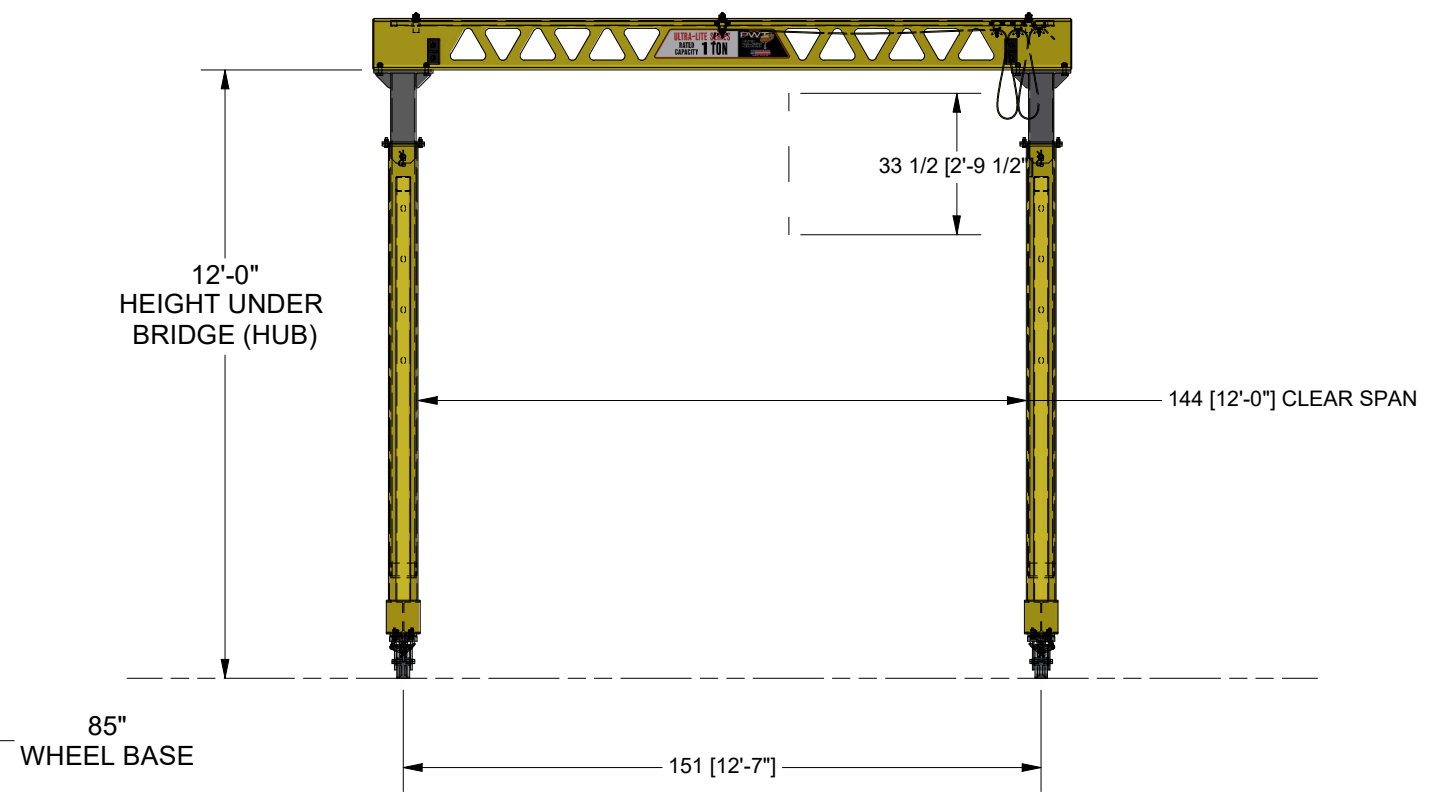

GANTRY QUANTITY : 2
GANTRY CAPACITY : 5 Ton
HOIST QTY : 1 PER SYSTEM
HOIST TYPE : ELECTRIC CHAIN HOIST
HOIST CAPACITY : 5 TON
HOIST BRAND : STARKE
HOIST MODEL : STK5011-10
HOIST VOLTAGE : 460V/3PH
TROLLEY MODEL : SHT500
HEADROOM : 33.5"

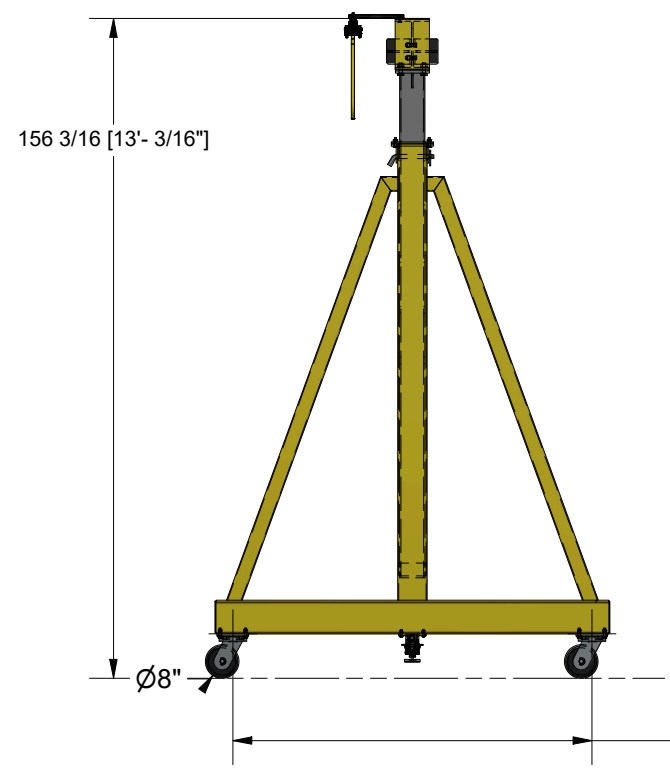
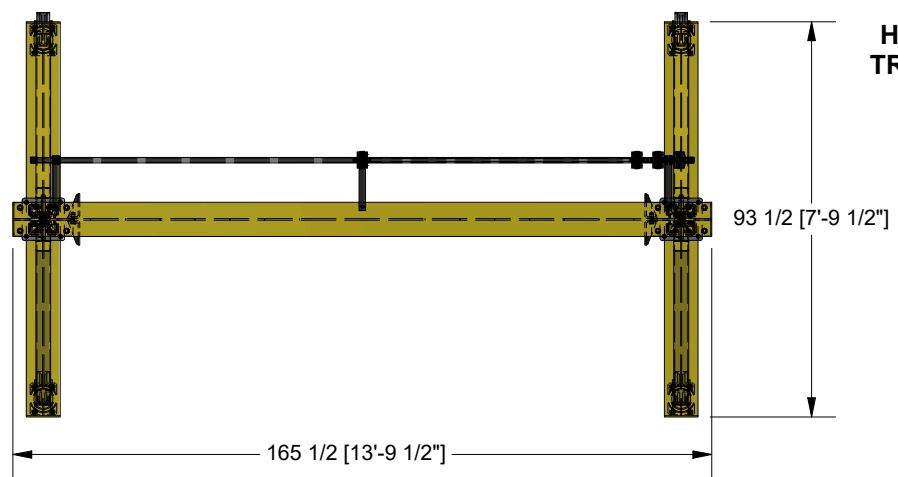

***QTY: 2**

SUBMITTAL REVIEW
CUSTOMER IS RESPONSIBLE TO VERIFY ALL DIMENSIONS.
SIGNED APPROVAL AUTHORIZES PWI TO PROCEED WITH SHOP FABRICATION AND INSTALLATION.

SHIPS WEEK OF 12/31 IF APPROVED BY 12/31

SIGN ABOVE FOR APPROVAL _____ DATE _____

JOB:
HOIST ZONE CUSTOMER
SAMPLE APPROVAL DRAWING
QUOTE

DRAWING:
GANTRY
QUOTE-GC-AS001

PAINT COLOR: SAFETY YELLOW		
SALESMAN: HOIST ZONE SALESMAN	TOLERANCES (U.N.O.): DIMENSIONS: ±1/8" ANGLES: ± 0.2°	

NOTE: SHIPS PARTIALLY ASSEMBLED

SHIPPING LIST

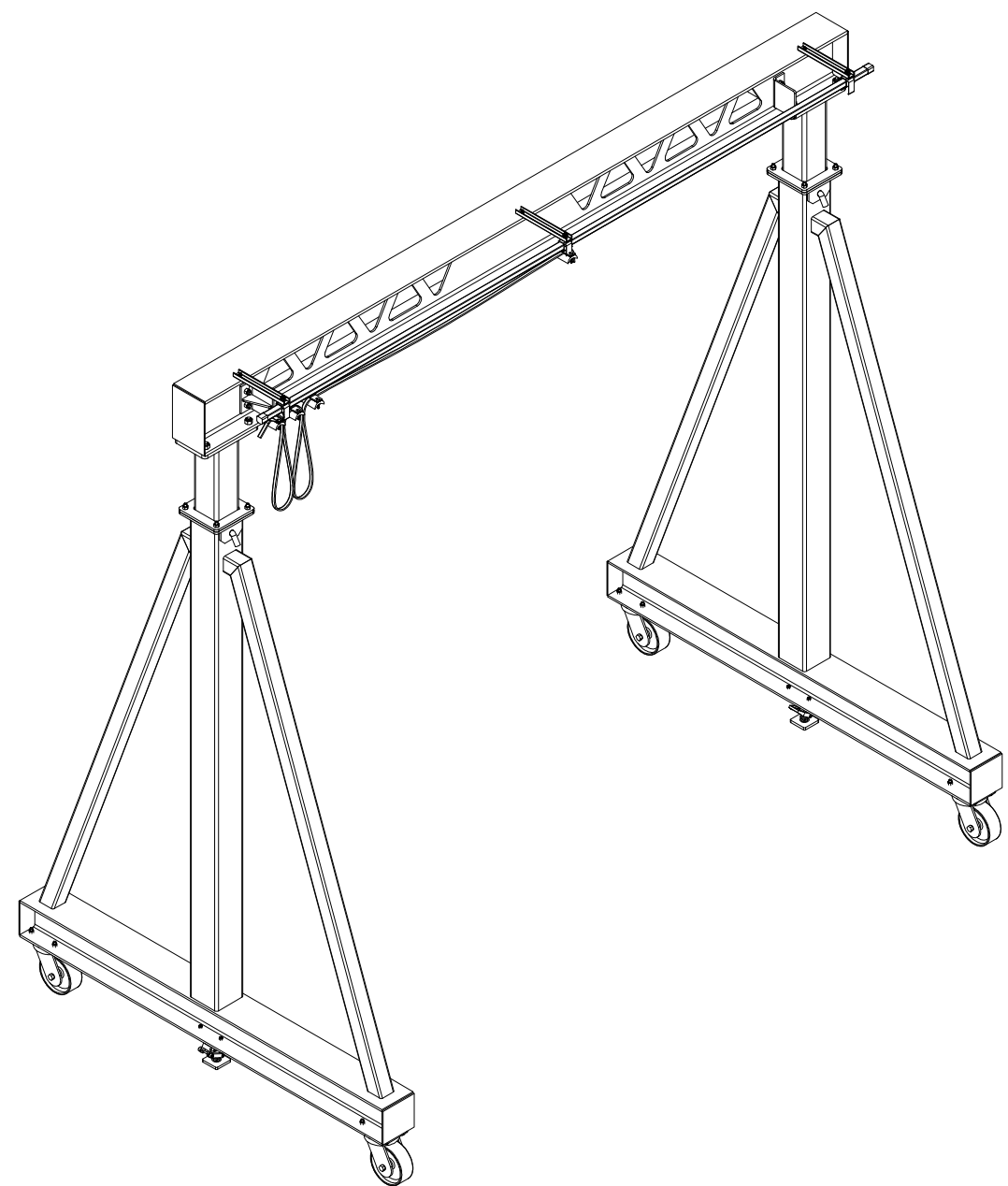

ITEM	QTY	PART NO.	DESCRIPTION	LENGTH	UNIT WT.	NET WT.	FINISH
1	2	QUOTE-GC-WD003	GANTRY BEAM WELDMENT		645.10	1290.21	SAFETY YELLOW
2	4	QUOTE-GC-AS002	EXTENDABLE LEG ASSEMBLY		876.87	3507.46	YELLOW, SAFETY
3	2	PL1689	ELECTROTRACK RUNWAY WELD ON BRACKET	7 in	0.95	1.9	UNFINISHED
4	4	90146A248	1IN X 8IN BENT CLEVIS PIN		2.63	10.53	PURCHASED
5	8	SET-90072	COPPER SPLICE CONNECTOR		0.04	0.3	
6	2	SET4-65	ELECTROTRACK 65AMP, CUT	4 3/8 in	0.25	0.49	
7	2	SET4-65	ELECTROTRACK 65AMP, FULL LENGTH	155 1/8 in	10.40	20.8	
8	8	SET-90075	ELECTROTRACK HANGER W/ HARDWARE		0.19	1.5	PURCHASED
9	2	SET-90068	END POWER FEED KIT		0.75	1.51	
10	8	ES6X6	END STOP - HEAVY DUTY		5.87	46.93	
11	6	-	FESTOON BRACKET (SELECT MEMBER!)	13 in	1.26	7.55	BLACK
12	2	S100-156	FESTOON TRACK		9.93	19.87	
13	6	S100-CFT	FESTOON TROLLEY		1.22	7.32	
14	2	S100-CET	FESTOON TROLLEY, CLAMP STYLE		1.15	2.29	
15	2	S100-AH	SINGLE BOLT ANCHOR HANGER		0.40	0.8	PURCHASED
16	4	S100-SH	SINGLE BOLT STANDARD HANGER		0.40	1.6	PURCHASED
17	2	SET-90071	SPLICE COVER SET		0.10	0.2	
18	8	SET-90076	STARKE ELECTROTRACK BRACKET - 13 IN	13 in	1.26	10.07	BLACK PAINT
19	4	S100-EC	TRACK END CAP		0.17	0.66	
20	16	-	3/8"-16 HEX BOLT (GR. 5)	1 1/2 in	0.01	0.14	ZINC-PLATED
21	6	-	3/8"-16 HEX BOLT (GR. 8)	1 1/2 in	0.01	0.05	YELLOW ZINC
22	16	-	3/8" FLAT WASHER (GR. 5)		0.00	0.03	ZINC-PLATED
23	16	-	3/8"-16 NYLON LOCKING NUT (GR. 5)		0.00	0.04	ZINC-PLATED
24	6	-	3/8"-16 NYLON LOCKING NUT (GR. 8)		0.00	0.02	YELLOW ZINC
25	32	-	1/2"-13 HEX BOLT (GR. 5)	2 in	0.02	0.66	ZINC-PLATED
26	16	-	1/2"-13 STRUCTURAL BOLT (A325)	2 in	0.02	0.35	BLACK OXIDE
27	32	-	1/2" FLAT WASHER (GR. 5)		0.00	0.16	ZINC-PLATED
28	16	-	1/2"-13 HEAVY HEX NUT (A563)		0.01	0.13	BLACK OXIDE
29	32	-	1/2"-13 NYLON LOCKING NUT (GR. 5)		0.01	0.19	ZINC-PLATED
30	8	-	5/8"-11 HEX BOLT (GR. 8)	2 1/4 in	0.04	0.3	YELLOW ZINC
31	8	-	5/8"-11 NYLON LOCKING NUT (GR. 8)		0.01	0.09	YELLOW ZINC
32	16	-	3/4"-10 STRUCTURAL BOLT (A325)	2 1/2 in	0.06	1	BLACK OXIDE
33	16	-	3/4"-10 HEAVY HEX NUT (A563)		0.02	0.38	BLACK OXIDE
34	4	-	M6 x 1 HEX BOLT x 12mm	1/2 in	0.00	0.01	ZINC
35	4	-	M6 x 1 HEX NUT		0.00	0	ZINC
36	2	-	4-14 FESTOON CABLE	241 in	20.00	40	PURCHASED
37	8	SCC-KP93S830-FST	8" X 3" SWIVEL CASTER, FORGED (11000# CAP)		39.99	319.94	ZINC-PLATED
38	4	FL-ADJ-810	ADJUSTABLE FLOOR LOCK		8.00	32	ZINC-PLATED
39	2	SET-90074	ELECTROTRACK END CAP		0.05	0.1	
40	2	SHT500	STARKE 5 TON MANUAL TROLLEY		81.20	162.4	PURCHASED
						TOTAL WT.#	5489.97

GANTRY CAPACITY: 5 Ton
HOIST TYPE: ELECTRIC CHAIN HOIST
HOIST CAPACITY: 5 TON
HOIST BRAND : STARKE
HOIST MODEL: STK5011-10
HOIST VOLTAGE: 460V/3PH
TROLLEY MODEL: SHT500

PAINT COLOR: SAFETY YELLOW		 HOISTZONE.COM <small>BY PWZ</small>
SALESMAN: HOIST ZONE SALESMAN	<small>TOLERANCES (U.N.O.): DIMENSIONS: ±1/8" ANGLES: ± 0.2°</small>	

JOB: HOIST ZONE CUSTOMER SAMPLE APPROVAL DRAWING QUOTE	DRAWING: GANTRY QUOTE-GC-AS001
--	--

Y:\Engineering\09 Engineering Staff\Johnathan McGurn\Sample Hoist Zone Approvals\Ultralite Telescoping Gantry Crane\GCU_Customer.dwg
Last Saved: 03-06-2025 @ 09:33:35 JOHN MCGURN (Sample Hoist Zone Approvals)