



OWNER'S MANUAL

Laser Kit

**Collision Avoidance
SCA-LZ-200T**

Dual Event – Twin Laser



Dual Event Twin LASER

Table of Contents

- 1.0 General Product Information..... 3**
 - 1.1 Warning 3
 - 1.2 General Information 3
 - 1.3 Compliance 3
- 2.0 Installation Guide 4**
 - 2.1 Mounting and Alignment..... 4
 - 2.2 Sensor Programming- (using Feet&Inches)..... 4
 - 2.3 Sensor Programming- (Setting Set Point 1)..... 4
 - (First Event Distance Q1 & Q3)..... 4
 - 2.4 Sensor Programming- (Enable Set Point 2)..... 4
 - 2.5 Sensor Programming- (Setting Set Point 2)..... 5
- 3.0 Factory Reset Instructions 5**
 - 3.1 Factory Reset Instructions (Do this only if required) 5
- 4.0 Pendant to VFD Settings (Optional)..... 5**
- 5.0 Parts..... 6**
- 6.0 Electrical Drawing 8**
- 7.0 Electrical Drawing10**
- Starke Products Warranty 11**

1.0 General Product Information

We would like to Thank you for purchasing a Starke collision avoidance kit. This manual covers installing the parts of this kit and provides instructions on how those parts work together to provide accurate collision avoidance that can prevent machine failures. Please read this entire manual before attempting to install your laser kit. This manual includes important information relating to your safety and the safety of others in the area where this is installed.

This Starke kit comes with

- (2) Laser Sensor Units
- (2) Sensor Mounting Brackets and Hardware
- (2) 10 Meter Data Cables
- (1) DIN Mounted Power/Relay Module
- (2) Reflector Arrays with Mounting Hardware
- Electrical Schematic Sheets
- Warning Labels

1.1 Warning

Make Certain that the power supply is disconnected before installing, repairing, or making adjustments to this device. This device is to be installed by qualified electrical personnel only.

This device incorporates IR Laser Protection Class 2: Visible Laser Light

DO NOT STARE INTO THE BEAM!

C1, C2, Relay coils are 120VAC rated

The Q1, Q2, Q3, Q4 coils are controlled by a 24VDC laser

This unit may not be suitable for all applications

Before installing you will need to confirm the unit will work with your application. A qualified technician must assess and approve the installation of the device on your equipment.

1.2 General Information

- Laser Class 2
- Max Power 4.1mW
- Time Base 100 s
- Pulse Duration 1.3 mS
- Wavelength 650nm

1.3 Compliance

21 CFR PART 1040 ENC60825-1:2003-10

2.0 Installation Guide

Use the following steps to mount, align, and program the device

2.1 Mounting and Alignment

Mount sensor and reflector using supplied bracket and hardware to suitable locations for stability and proper alignment. Use 3 point alignment method to ensure the laser and reflector are in a straight line, both horizontally and vertically true.

Connect the supplied Laser Warning Label in the immediate vicinity of the sensor unit.

Proceed to attach 110VAC to the transformer per the schematic drawing. A visible red light will be seen from the sensor to the reflector. **DO NOT LOOK INTO THE LASER LIGHT!**

2.2 Sensor Programming- (using Feet&Inches)

(All Button presses must be done within 15 seconds)

2.2.1 Press and release the **Mode/Enter** button until **EF** is displayed. (multiple presses)

2.2.2 Press and release the **SET** button.

2.2.3 Press and release the **Mode/Enter** button until **Uni** is displayed. (6 button presses)

2.2.4 Press and hold the **SET** button until **FEET** is displayed, and release.

2.2.5 Press and release the **Mode/Enter** button once to confirm.

2.2.6 Wait 15-20 seconds and the unit will return to the “run” mode.

2.2.7 When sensor is in Run mode, distance to target is displayed in feet.

2.3 Sensor Programming- (Setting Set Point 1)

(First Event Distance Q1 & Q3)

(All Button presses must be done within 15 seconds)

2.3.1 Press and release the **Mode/Enter** button until **SP 1** is displayed. (2 presses)

2.3.2 Press and hold the **SET** button until the desired distance for the first event is displayed, then release.

2.3.3 NOTE: Minimum distance is 1 meter (3.28 feet).

2.3.4 Press and release the **Mode/Enter** button once to confirm. The display will show SP 1.

2.3.5 Wait 15 to 20 seconds and the unit will return to the “run” mode.

2.4 Sensor Programming- (Enable Set Point 2)

(All Button presses must be done within 15 seconds)

2.4.1 Press and release the **Mode/Enter** button until **OU2** is displayed. (3 presses)

2.4.2 Press and hold **SET** button until **Hno** is displayed, then release.

2.4.3 Press and release the **Mode/Enter** button to confirm.

2.4.4 Wait 15 to 20 seconds and the unit will return to the “run” mode.

2.5 Sensor Programming- (Setting Set Point 2)

(Second Event Distance Q2 & Q4)

2.5.1 Press and release the **Mode/Enter** button until **SP 2** is displayed. (4 presses)

2.5.2 Press and hold the **SET** button until the desired distance for the second event is displayed, then release.

2.5.3 NOTE: Minimum distance is 1 meter (3.28 feet).

2.5.4 Press and release the **Mode/Enter** button once to confirm. The display will show **SP 2**.

2.5.5 Wait 15 to 20 seconds and the unit will return to the “run” mode.

****REPEAT STEPS FOR 2ND SENSOR****

THE LASER COLLISION AVOIDANCE SYSTEM SHOULD NOW BE READY TO OPERATE. PLEASE ENSURE THAT THE LED'S ON THE CONTROL UNIT LIGHT WHEN CRANE IS MOVED TO EACH SET POSITION.

3.0 Factory Reset Instructions

Only if required

3.1 Factory Reset Instructions (Do this only if required)

3.1.1 In the event that improper selections were made during the previous sensor programming steps, it may be necessary to reset the unit to factory settings. Perform the following steps **ONLY** if required or the sensor is not responding as intended.

3.1.2 Press and release the **Mode/Enter** button until **EF** is displayed. (multiple presses required)

3.1.3 Press and release the **SET** button once.

3.1.4 Press and release the **Mode/Enter** button until **rES** is displayed 5. Press and hold **SET** button until ---- (4 dashes) is displayed

3.1.5 Confirm by pressing the **Mode/Enter** button once.

3.1.6 After performing the factory reset you must repeat the SENSOR PROGRAMMING steps outlined in the steps above.

4.0 Pendant to VFD Settings (Optional)

4.1 SCA-LZ-200 includes two extra relays that make it possible to split the 2nd speed from your pendant into two separate signals to the VFD drive. You will need to change your drive settings from infinitely variable to stepping.*****

The C1,C2 contacts are rated 120VAC. If you need a 24VDC rated coil, please consult the factory. The Q1,Q2,Q3,Q4 relays are controlled by a 24VDC laser.

C1 is controlled by the Q2 Forward relay.

C2 is controlled by the Q4 Reverse relay.

Q1 is Forward 2nd speed.

Q3 is Reverse 2nd speed.

5.0 Parts

5.1 Mounting Brackets with Hardware (qty 2)



5.2 Laser (qty 2)



5.3 Harness (qty 2) and DIN rail (qty 1)



5.4 Reflectors (qty 2)



6.0 Electrical Drawing

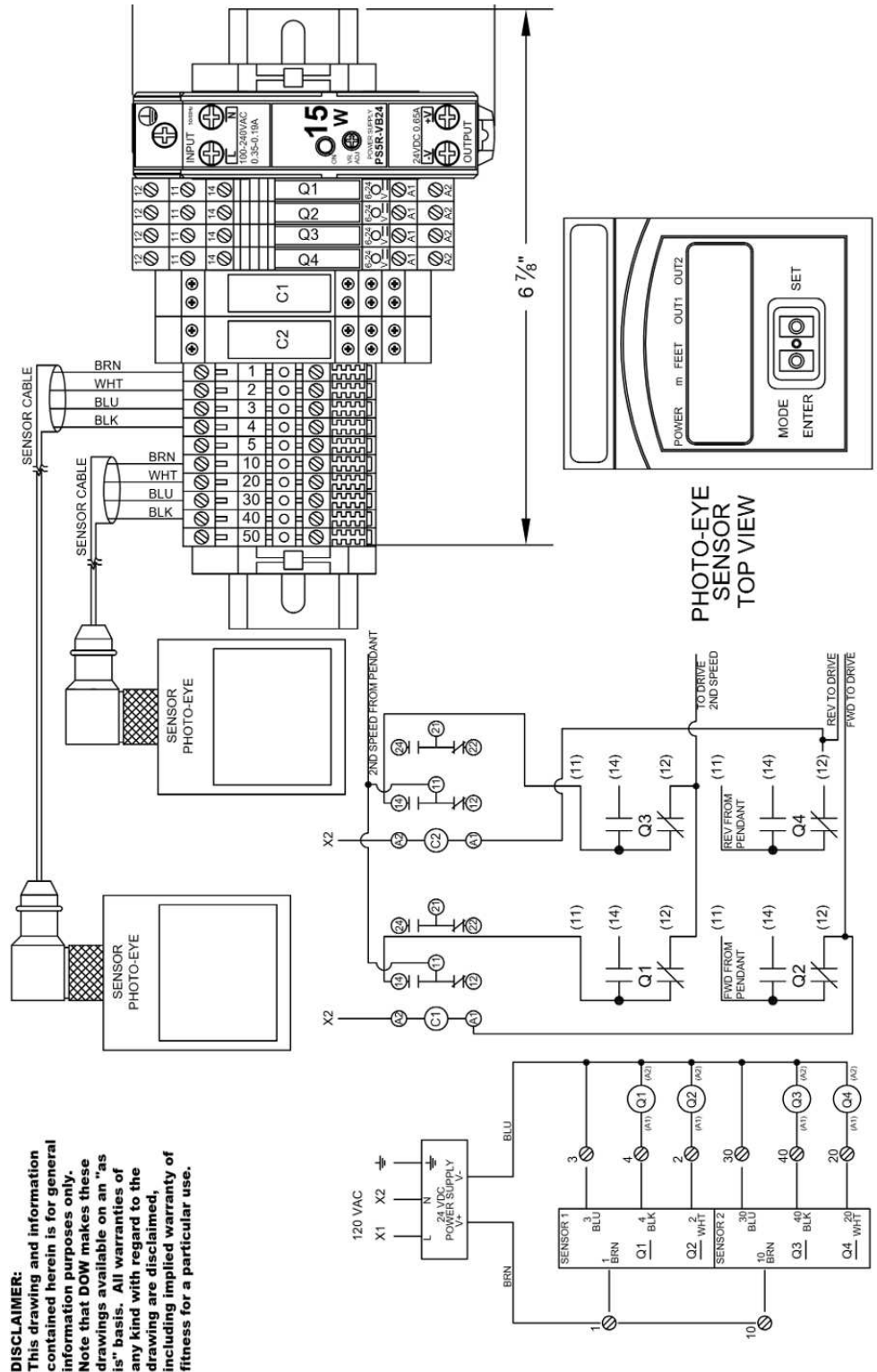

Collision Avoidance Kits

SKU	Description	Application	Net Weight
SCA-LE-50S	Single Event LED	Simple uni-directional bridge collision avoidance with (1) adjustable event (0-50 ft)	3 lbs
SCA-LE-50T	Single Event Twin LED	Simple uni-directional bridge collision avoidance with (2) adjustable events (0-50 ft)	5 lbs
SCA-LZ-200S	Dual Event Single LASER	Precision uni-directional bridge collision avoidance with (2) programmable events (0-200ft)	5 lbs
SCA-LZ-200T	Dual Event Twin LASER	Precision bi-directional bridge collision avoidance with (2) programmable events (0-200ft)	8 lbs

- All kits include LED or LASER device(s), mounting brackets, reflector(s) on mounting bracket, control cable(s), and any required relay controls
- An “Event” is simply a measurable action that can dictate the speed or the stopping of the moving crane. A single laser may have dual events, but can still only point in one direction, which may require a “Twin” system if there are functions to be controlled in both directions



Single Event LED



Single Event Twin LED



Dual Event Single LASER



Dual Event Twin LASER

7.0 Electrical Drawing

When used in a bridge crane or hoist operation the twin laser kit is designed to provide two events in each direction from your bridge crane or hoist. An “event” is simply a measurable action that can dictate the speed or provide a signal to stop an electrically controlled object’s motion. A single laser may have dual events but can still only point in one direction. You will require a dual event twin laser system if you want to provide events in both directions from your bridge crane or hoist set up.

Below are some examples of how many kits you may need for multiple bridge crane systems.

This twin laser kit includes 2 units (lasers)

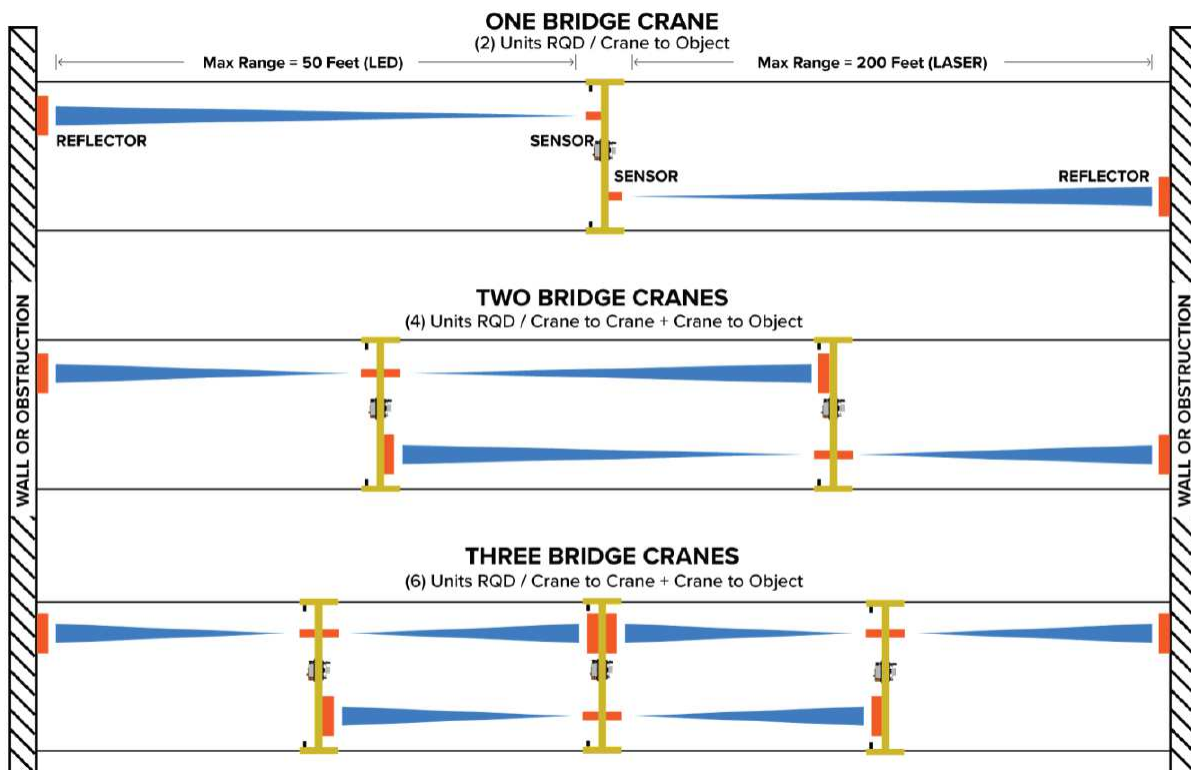



Starke Products Warranty

1 Year (12 Month) Parts & Labor Warranty

Unless otherwise specified, Starke guarantees that our products are free from material defects in design and workmanship under normal use, proper maintenance, and service.

This warranty is strictly limited to 12 months for single shift operation or 2,000 hours after installation, or 14 months after shipment, whichever is shorter. Within ten days after defect is found, warrantee must deliver a written notice to Starke providing defect information. All requested warranty information must be received promptly by Starke in no more than 5 business days.

Customer is responsible for all shipping charges on returned/warrantable items. Starke will cover the repair (parts and labor) at no charge or provide a replacement item at Starke's discretion.

This warranty does not cover defects or damage caused by acts of God, unusual wear and tear, improper use, or improper maintenance by the user. No responsibility for consequential damage is expressed or implied, and the responsibility under this warranty/guaranty is limited to the repair or replacement of the defective materials. Repair or replacement of the item is fully at the discretion of Starke.

ALL OTHER REPRESENTATIONS, EXPRESS OR IMPLIED, WARRANTY, OR LIABILITY RELATING TO THE CONDITION OR USE OF THE PRODUCT ARE SPECIFICALLY DISAVOWED, AND IN NO EVENT SHALL STARKE BE LIABLE TO BUYER, OR ANY THIRD PARTY, FOR ANY DIRECT OR INDIRECT CONSEQUENTIAL OR INCIDENTAL DAMAGES

STARKE
Starkeamerica.com/contact-us/

(Intentionally Left Blank)



Contact Your Starke Representative for More Information on Products to Help Maximize Your Workplace Efficiency



Hoists & Trolleys



Crane Components



Electrification



Crane Kits



Slings



Safety

