

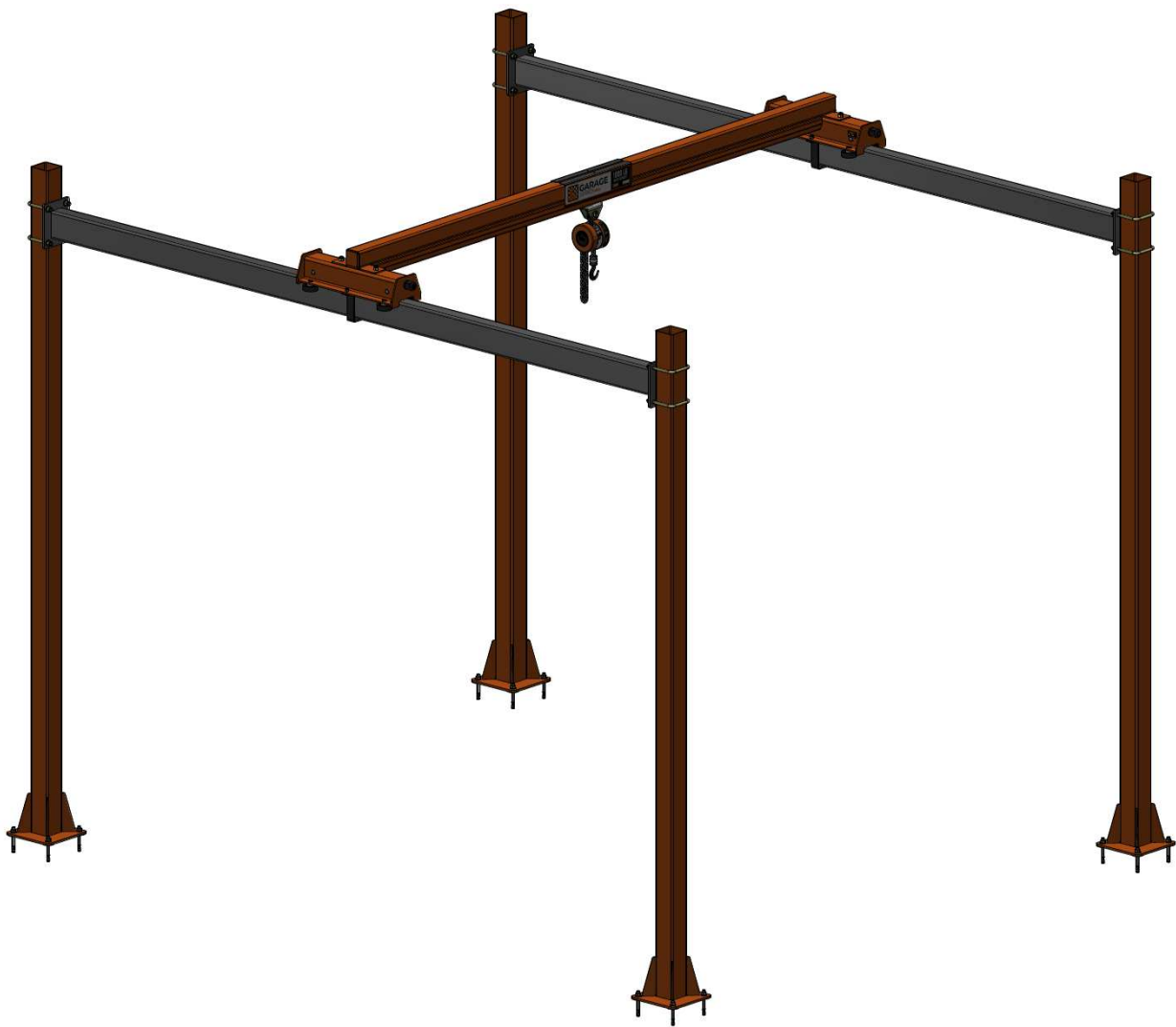

Garage Series Crane System- Top Runner Installation, Operation, & Maintenance Manual



OWNERS RECORDS

Date purchased _____

Serial Number _____

Order Number _____

TABLE OF CONTENTS

Safety	4
Pre-Installation Checklist & Capacity info	5
Basic Drawing	6
Pre-assembly & Column Installation	16
Runway Installation	17
Bridge Installation on Runways/Parts List	17
Bridge Crane Kit Parts List	18
(Optional) Electrification Instructions and Parts List	19
Crane Operator Instructions	20
Rolling Bridge and Rolling Trolley Motions	21
General Safety & Operating Suggestions	22
Warranty Information	25
Inspections & Lubrication	27
Customer Notes	28

Congratulations!

The PWI Crane System you have purchased was built for years of maintenance free operation. Its simple design and durability are the result of years of building crane systems for our local customers. We take pride in our products, and we want you to be completely satisfied with the operation of your new PWI Garage Series crane system. Please remember that our #1 goal for this manual is that you will have a successful installation and be very satisfied with your new crane and how it operates.

Before you begin. Read the instructions carefully, from beginning to end, and follow the proper sequence. On the next page you'll find a safety section and general checklist that you should read before starting your installation.

Thank you from all of us at PWI.

PWI
7930 W 1000 N
Nappanee IN 46550

pwiworks.com
Phone: 574-646-2015
email: sales@pwiworks.com

General Safety

Safety comes first when unloading and assembling your bridge crane system. Many of the components are heavy and require lifting tools to move and set them in place. Make sure the equipment you choose to support and lift each piece is capable of the task with extra capacity to do the job so that you do not end up in a dangerous situation.

Start with checking any lifting fixtures/tools for damage or wear that could lead to severe injury or death.

This manual assumes that you have performed any foundation work ahead of placing your crane system columns in their proper location. Failure to provide a level surface or enough floor thickness to anchor your crane properly could result in someone's injury or death. Please call PWI if you are unsure of the requirements for your PWI Crane System.

WARNING: THE CLEARANCES AROUND THE ROLLING PORTION OF YOUR BRIDGE CRANE ARE IMPORTANT! THERE MUST BE 3 INCHES ABOVE AND 2 INCHES ON THE SIDES OF THE ROLLING PORTION OF YOUR CRANE TO ANY OBSTRUCTION OR PART OF YOUR BUILDING.

Pre-Installation Checklist:

- Check your shipment for the correct components and hardware. Your shipment should include shipping sheets that were checked off by our team
- Check your shipment for drawings for layout and installation of components
- Clear the area as much as possible of items that could be damaged or create hazards during the installation. When assembling near Electrical panels be aware of any regulations regarding perimeters required around those objects
- Forklift or suitable lifting equipment
- Should you have any technical questions, or feel you have defective components or missing items, call us immediately. We will be glad to assist you.

Tools

- Markers, Tape Measures, Chalk Line, and Square
- Ladders/Man Lifts
- Hammer, Prybar, Clamps, and Line Up Punches, Metal File
- Torque Wrench, Hand Wrenches, and Socket Set
- Leveling Tools (Level, Water Level, Laser Level)
- Lifting Equipment

System Capacity Information

The innovative design and heavy-duty construction of the PWI Garage Series system will provide a superior quality product that will offer years of long-term value. The hoist weight allowance is 15% of the cranes capacity (for example, a crane rated for 1000 pounds allows for a 1000-pound live load plus 150 pounds for the weight of the hoist). There is also an allowance of 15% of the crane capacity for impact caused by hoist use. PWI Garage Series systems will provide many years of dependable service by following the installation and maintenance procedures described herein.

Note: Any dimensions shown in this manual are for illustration purposes only. Refer to the drawings that were sent with your system for the exact measurements and configuration of the system we built for you.

8' Bridge and 10' System Layout Drawing

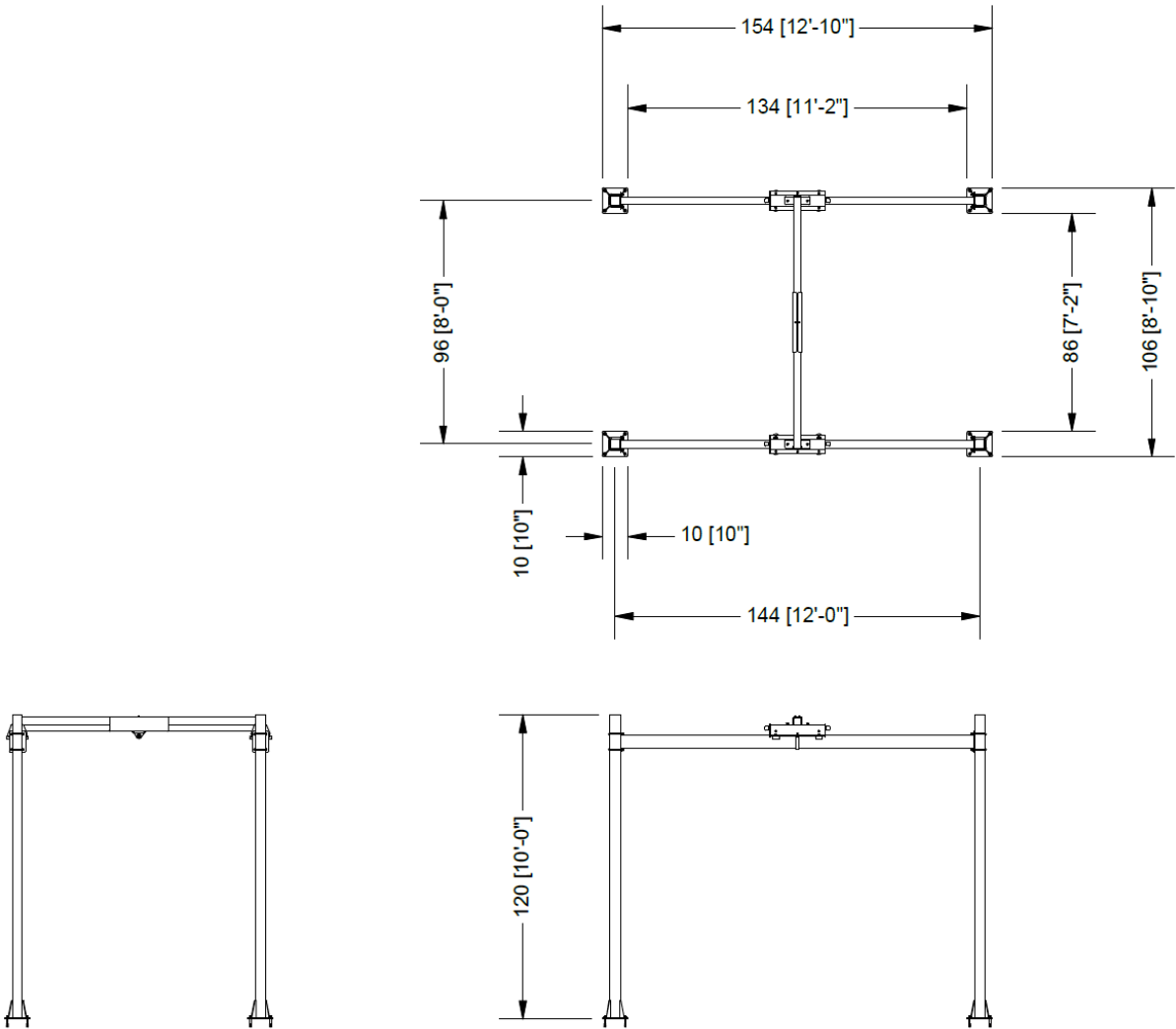

8' Bridge and 16' System Layout Drawing

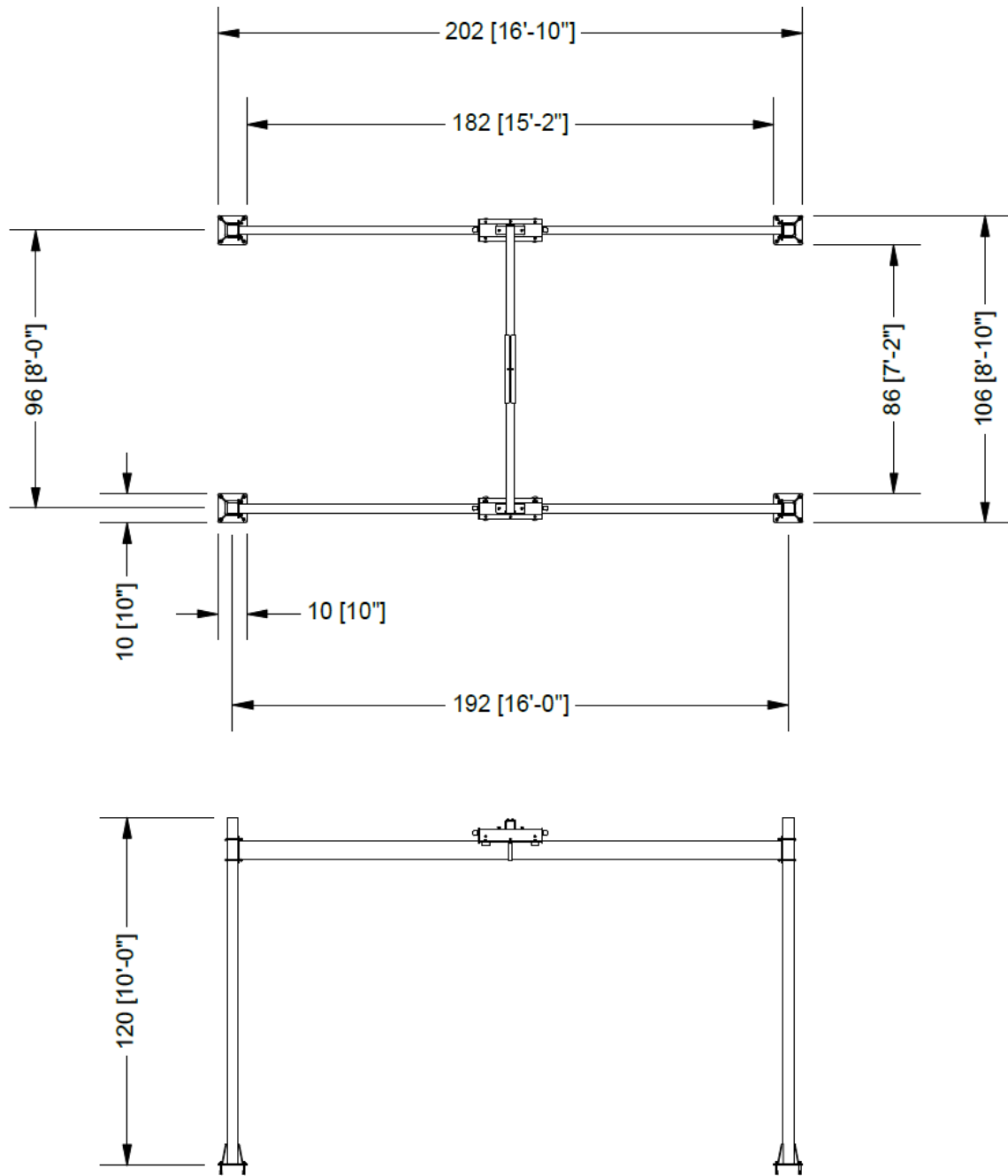

10' Bridge and 12' System Layout Drawing

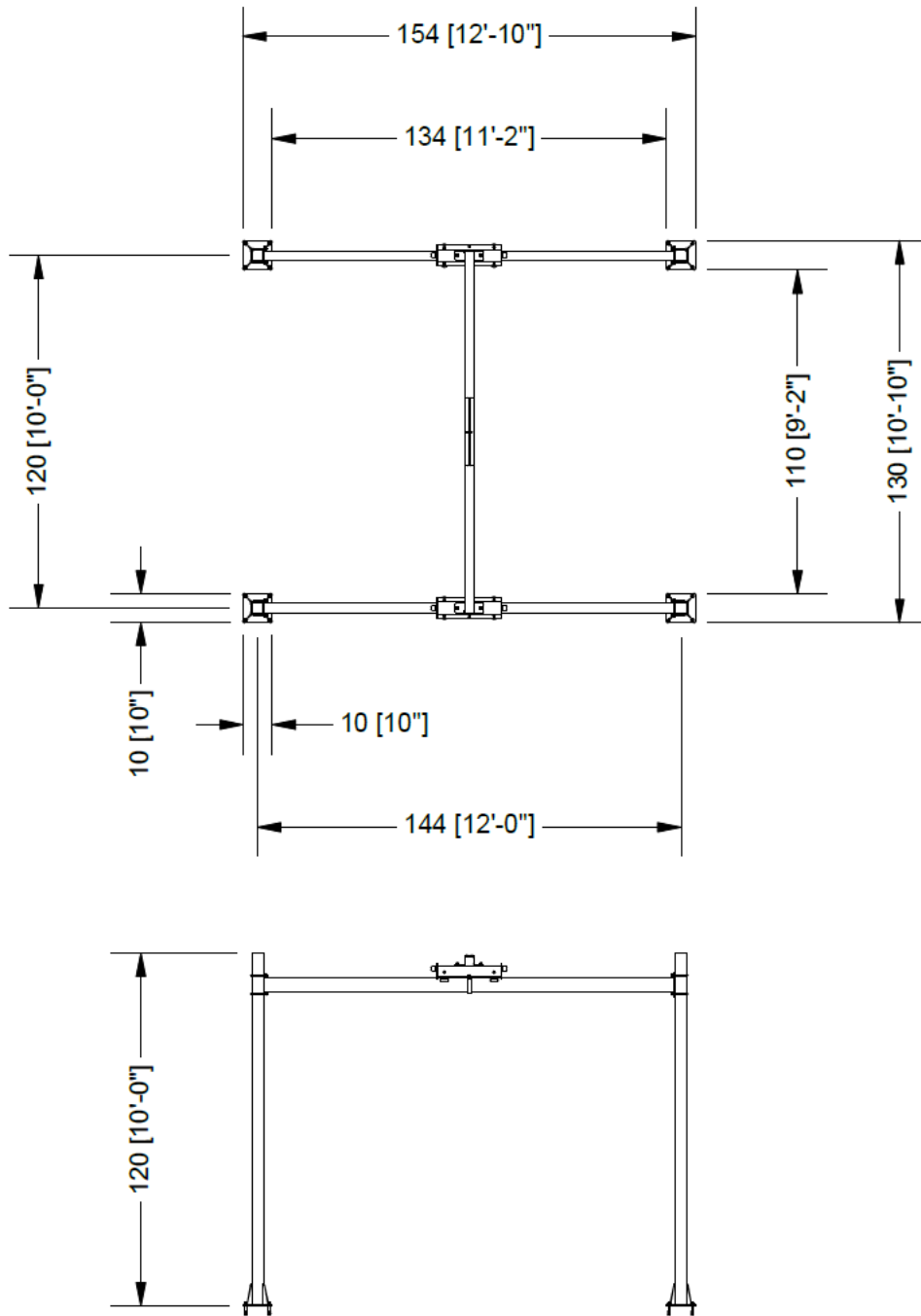

10' Bridge and 16' System Layout Drawing

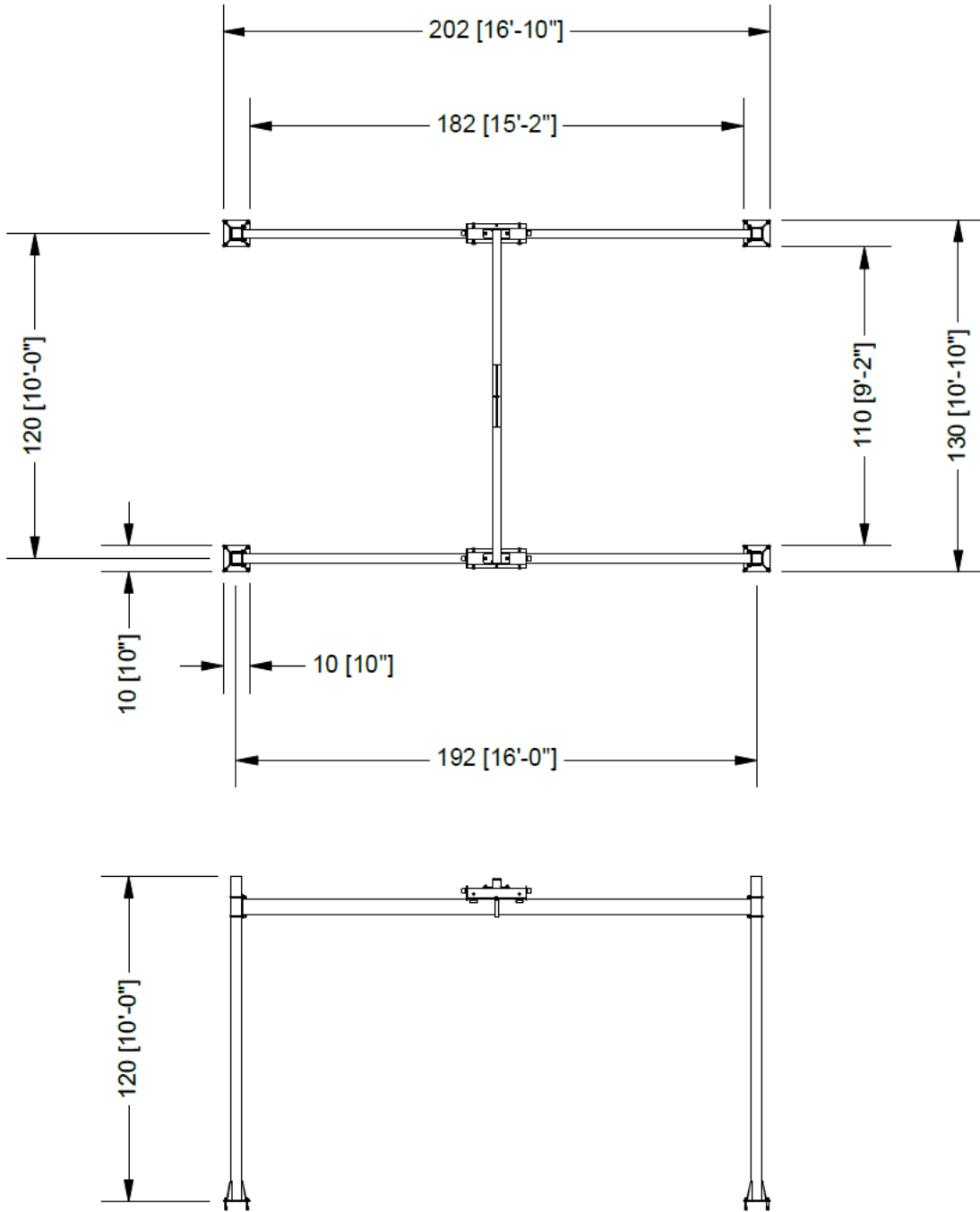

10' Bridge and 20' System Layout Drawing

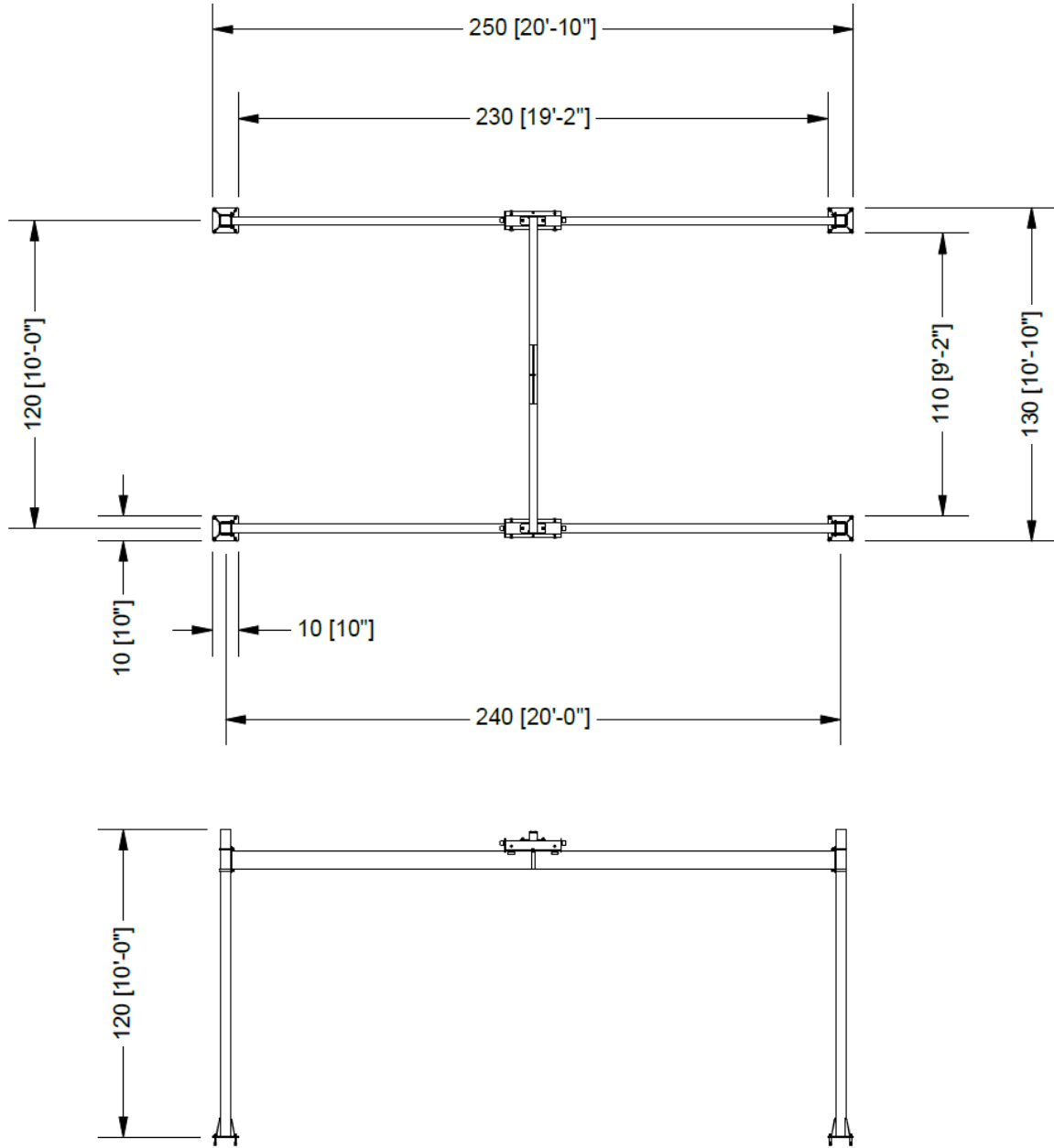

12' Bridge and 16' System Layout Drawing

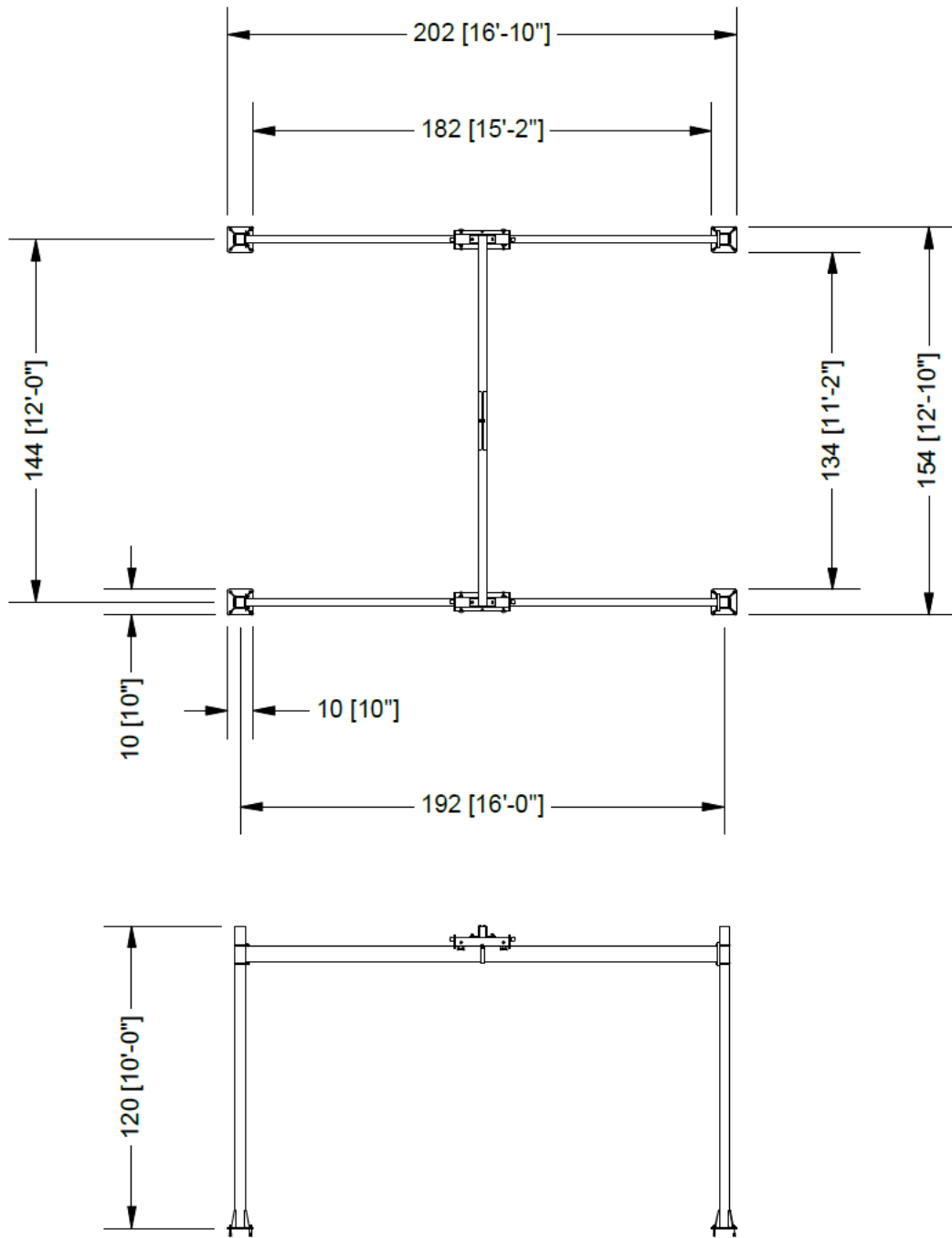

12' Bridge and 20' System Layout Drawing

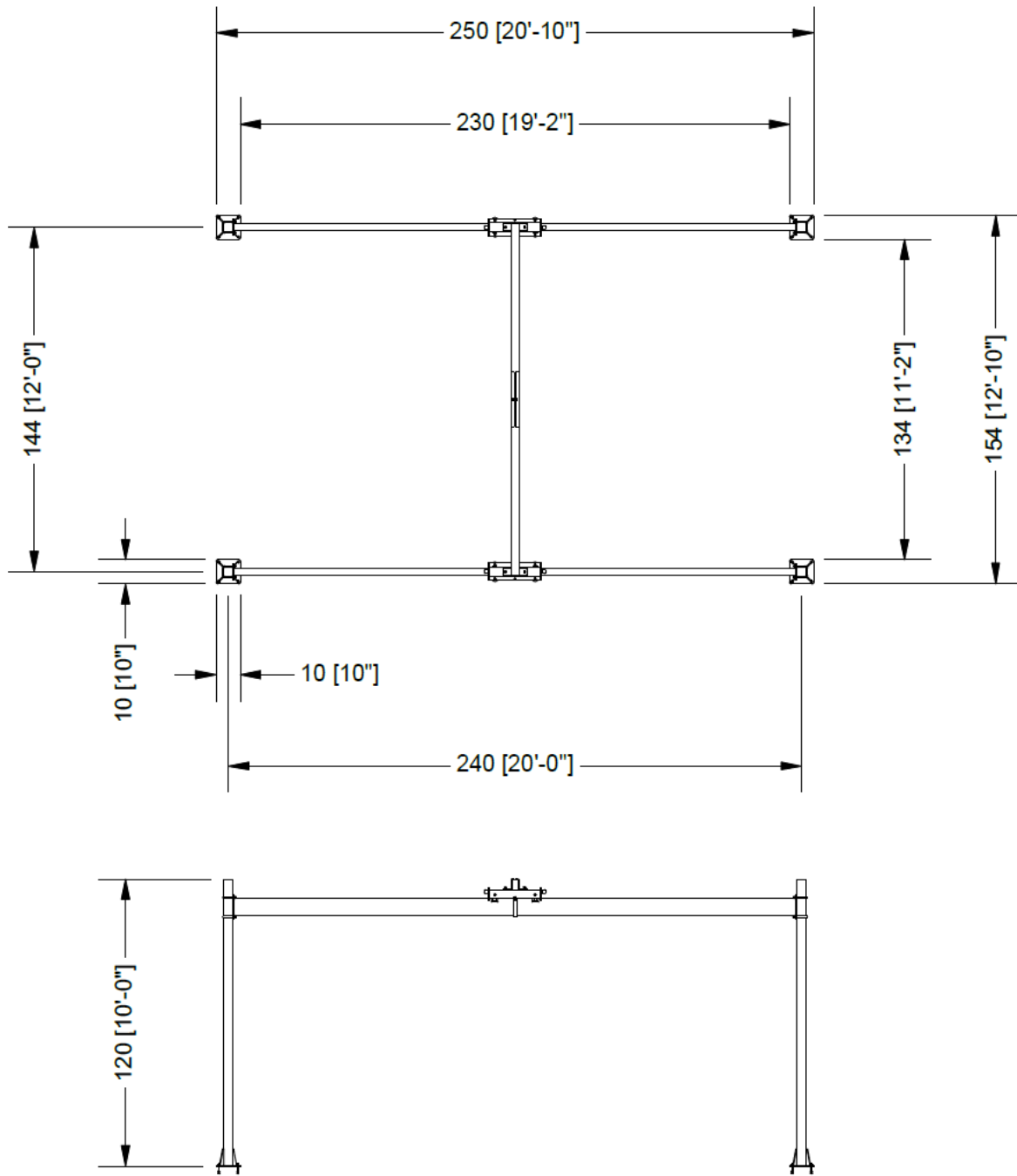

12' Bridge and 24' System Layout Drawing

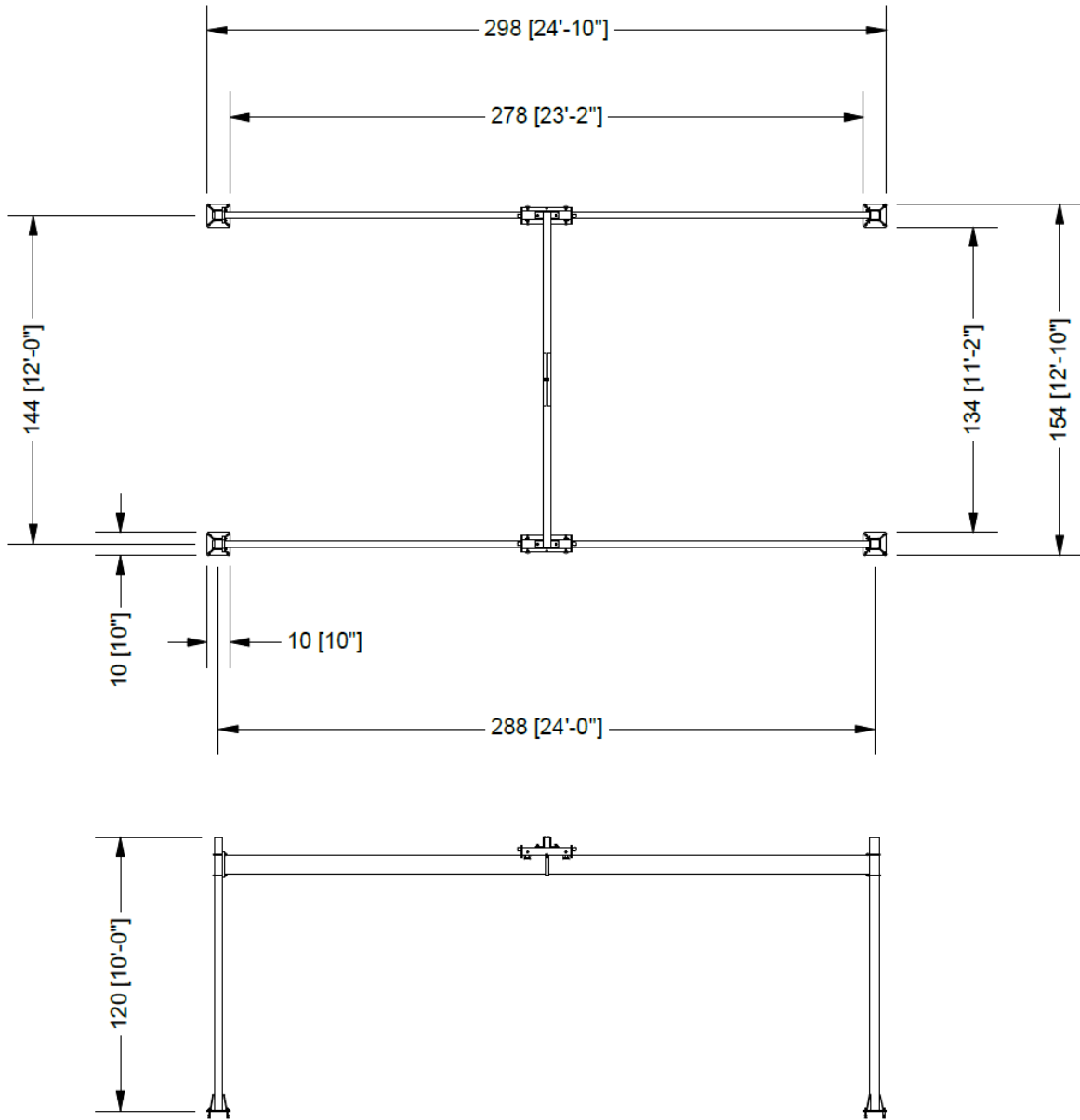

16' Bridge and 20' System Layout Drawing

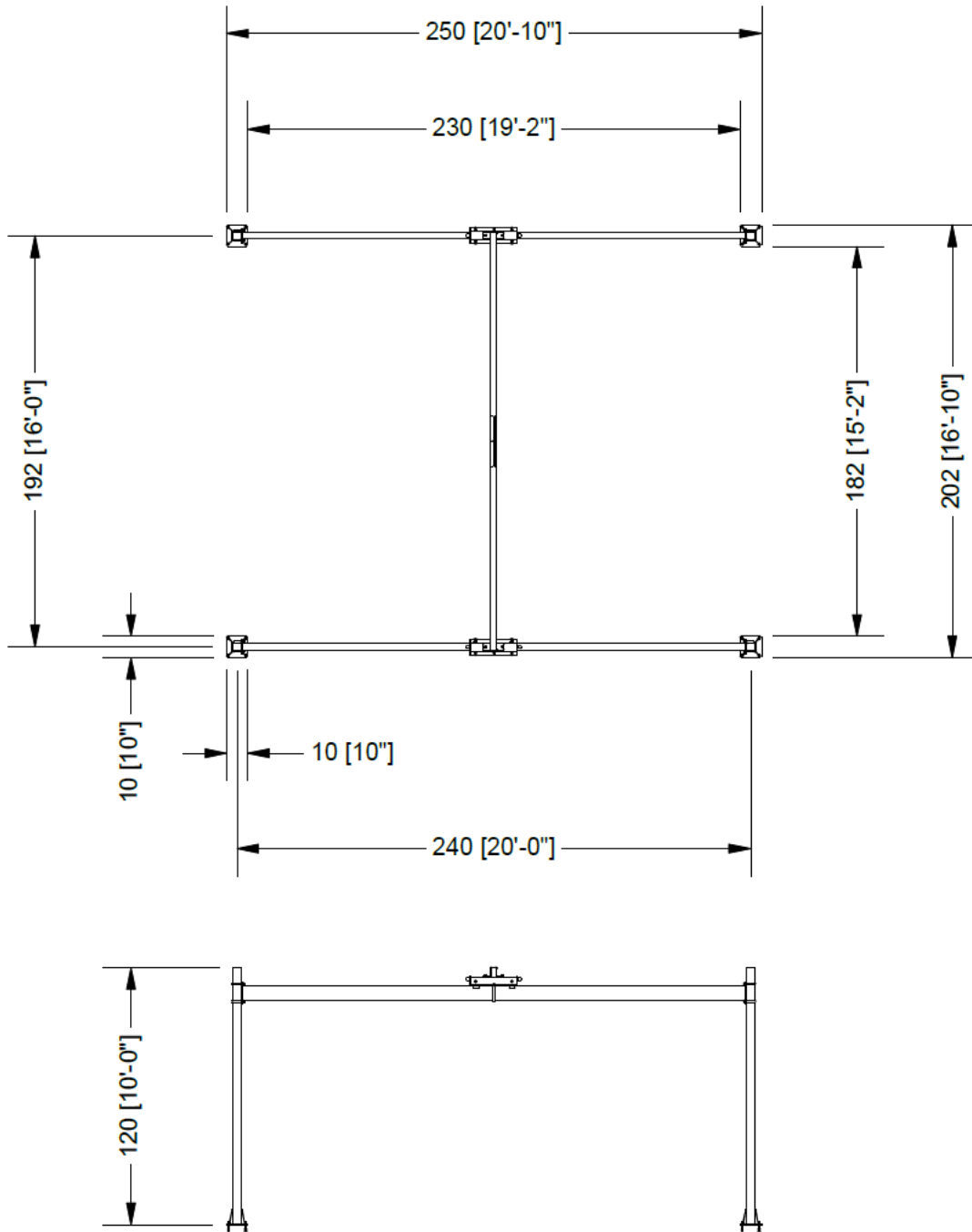

16' Bridge and 24' System Layout Drawing

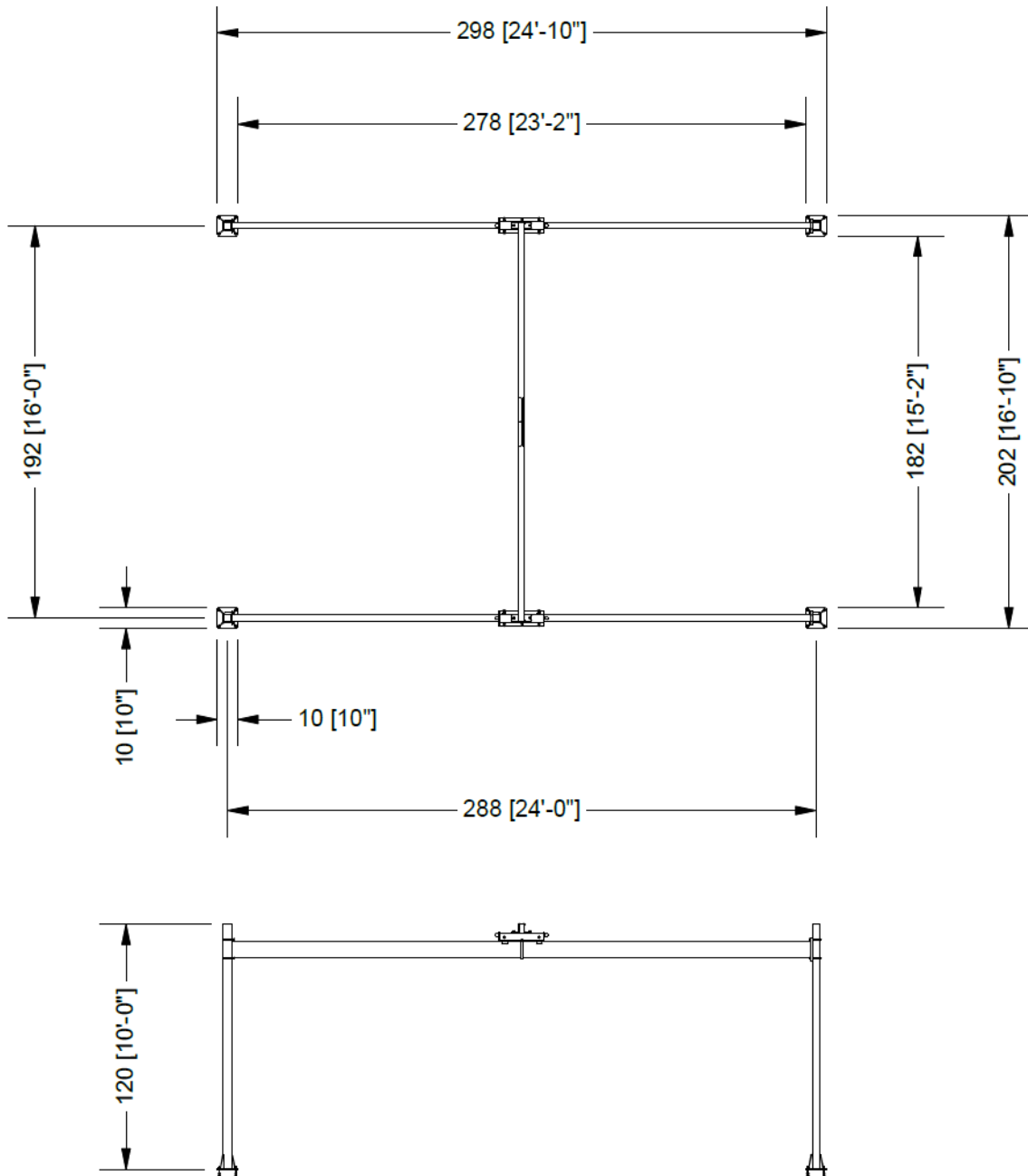

Step 1. Pre-Assembly

- 1.1 If your floor surface is uneven grout under the column bottom base plates will be required to provide a level foundation to build on. Leveling nuts under the column base plate is also an acceptable method that will aid leveling your system. (Shimming and leveling nuts and epoxy anchors are not supplied with your system). If you must grout under your columns to get a level system, the use of epoxy anchor bolts (not included) is recommended. Epoxy anchors need to withstand 4880lbs of pull force. Contact PWI if you have questions.

Step 2. Laying Out Your Columns

- 2.1 Using the drawings supplied with your system, verify that the area you are placing the crane system in will not encounter unforeseen obstructions. **Mark on the floor the center point of each column.** Look for obstructions that would require moving the system to avoid interference with items in your area. (Example – proximity to electrical panels and controls, doors and walkways, wall switches, garage door openers & tracks, overhead obstructions).
- 2.2 Once you have found the best place for your system and have marked the column centers, check that your marks are “square” by measuring diagonally from column center to column center. Once your system layout is correct and square you can **measure out from the center mark that you have made and sketch on the floor the outline of the column base plates.**
- 2.3 Measure to verify that the column is not too tall for the area. Cut off any excess column at the open end of the column tube. File smooth any sharp edges for safety. Stand the column up with a suitable lifting device and have help available to help hold the column in place while only drilling (2) of the anchor holes for now. Drill the (2) holes (check your paperwork supplied for sizes and torque specs of the anchor hardware) diagonally across from each other to temporarily anchor the columns. Hint – Drill completely through the concrete floor. (The minimum depth from the top of the finished floor is 4 inches)

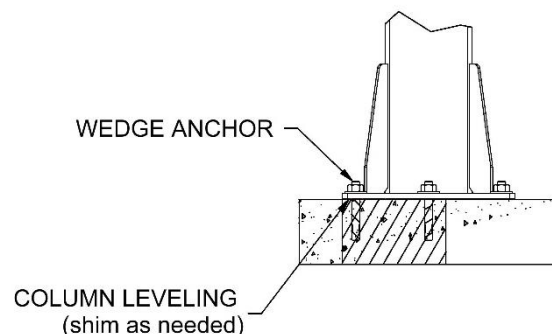

Step 3. Runway Installation

- 3.1 Once all 4 columns are temporarily anchored with 2 anchors each, find the included U-bolts and install the runways per the picture on the front of this book.
- 3.2 Support a runway with a suitable lifting device and move into position between the columns.
- 3.3 Important!** For stability of the system, the top of bridge tube can be no higher than the top of your column. (10') Make sure to measure the bridge while on the floor with end trucks installed. Measure from floor to top of bridge crane beam while bridge end trucks are on the floor. Use that measurement to mark your column for runway height. Using that measurement proceed to mark the column measuring down from the top of the column tube and making a horizontal line. Mark all columns. This will be the height to set the top of the runway TUBE.
- 3.4 Using hardware, attach the runway end plates to the columns using the supplied U-bolts, flat washers, and nuts. Tighten the U-bolts at this time.

Bolt Size	Torque
1/2"	55 lb/ft
9/16"	70 lb/ft
5/8"	95 lb/ft
3/4"	160 lb/ft
7/8"	190 lb/ft
Grade 8 Required	

Bolt Torque Chart

Step 4. Bridge Crane Installation on Runways

- 4.1 Your PWI Garage Series rolling bridge may need assembly.
- 4.2 Assemble End trucks to bridge beam with axle pin hardware facing in.

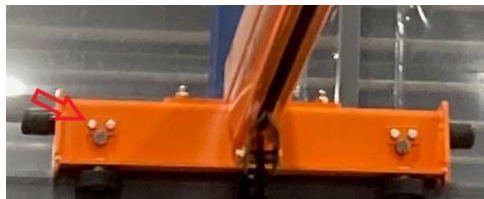

4.3 Install bridge by setting Garage Series bridge on top rail of runway. Verify all fasteners are tight.

4.4 Install end truck bridge lock bracket at this time.

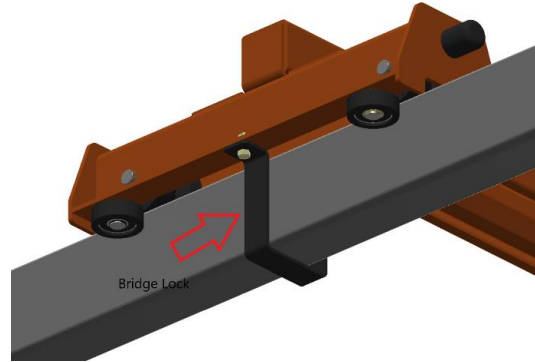

WARNING: THERE MUST BE A MINIMUM OF TWO THREADS SHOWING AT THE END OF THE BOLT AFTER THE NUT IS INSTALLED AND TIGHTENED.

Parts List

Item	Qty	Part Number
Column	4	800-10000
Column U-bolt	8	800-10001
Nut (U-bolt)	16	800-10002
Runway Tube	2	800-10003
Bridge Beam	1	800-10004
Bridge Lock Bracket	2	800-10005
End Truck Kit	2	800-10006
Trolley	1	SPT300
Bumper (rubber)	4	600-50035

Step 5. (Optional) Hoist Electrification Cable Kit

If you purchased the hoist electrification tagline kit, please follow these steps for proper installation on the runways and bridge. You will need to cut the cable to fit the length of one of the runways leaving 12" extra to loop back under the clamp at each end. Cut a separate piece of cable, leaving extra to loop back under the clamp, to fit the length of your bridge.

- 5.1 Lay out all the parts of the kit (use the following parts list as a guide)
- 5.2 Measure the length of the runway and cut the cable 2' longer than this length.
- 5.3 Attach the runway cable mount brackets to the runway u bolts as shown. (next page illustration)
- 5.4 Route the cable through 1 of the brackets and use 2 cable clamps to fasten the loose end of the cable (approx. 10") back to the cable itself making a small loop. Fasten a turnbuckle to the other runway clamp and then lengthen the turnbuckle to make it as long as possible.
- 5.5 Add enough rings to the cable length to support the electrical wire every 3 ft.
- 5.6 Make another loop on the other end of the cable.
- 5.7 Do not over tighten the turnbuckle when setting the steel cable tension. Use only enough force to pull the cable tight enough to support the weight of the electrical wire. This does not require excess force.

Repeat these steps for the bridge crane tag line kit.

Electrification Parts List

Item	Qty	Part Number
Runway cable (cut)	1	800-10025
Runway cable brackets	2	800-10026
Runway cable clamps	2	800-10027
Runway tagline rings	3' spacing	800-10028
Runway turnbuckle	1	800-10029
Bridge beam cable (cut)	1	800-10030
Bridge beam cable brackets	2	800-10031
Bridge beam cable clamps	2	800-10032
Bridge beam tagline rings	3' Spacing	800-10033
Bridge beam turnbuckle	1	800-10034
Zip ties	as req'd	

Tag Line Illustration

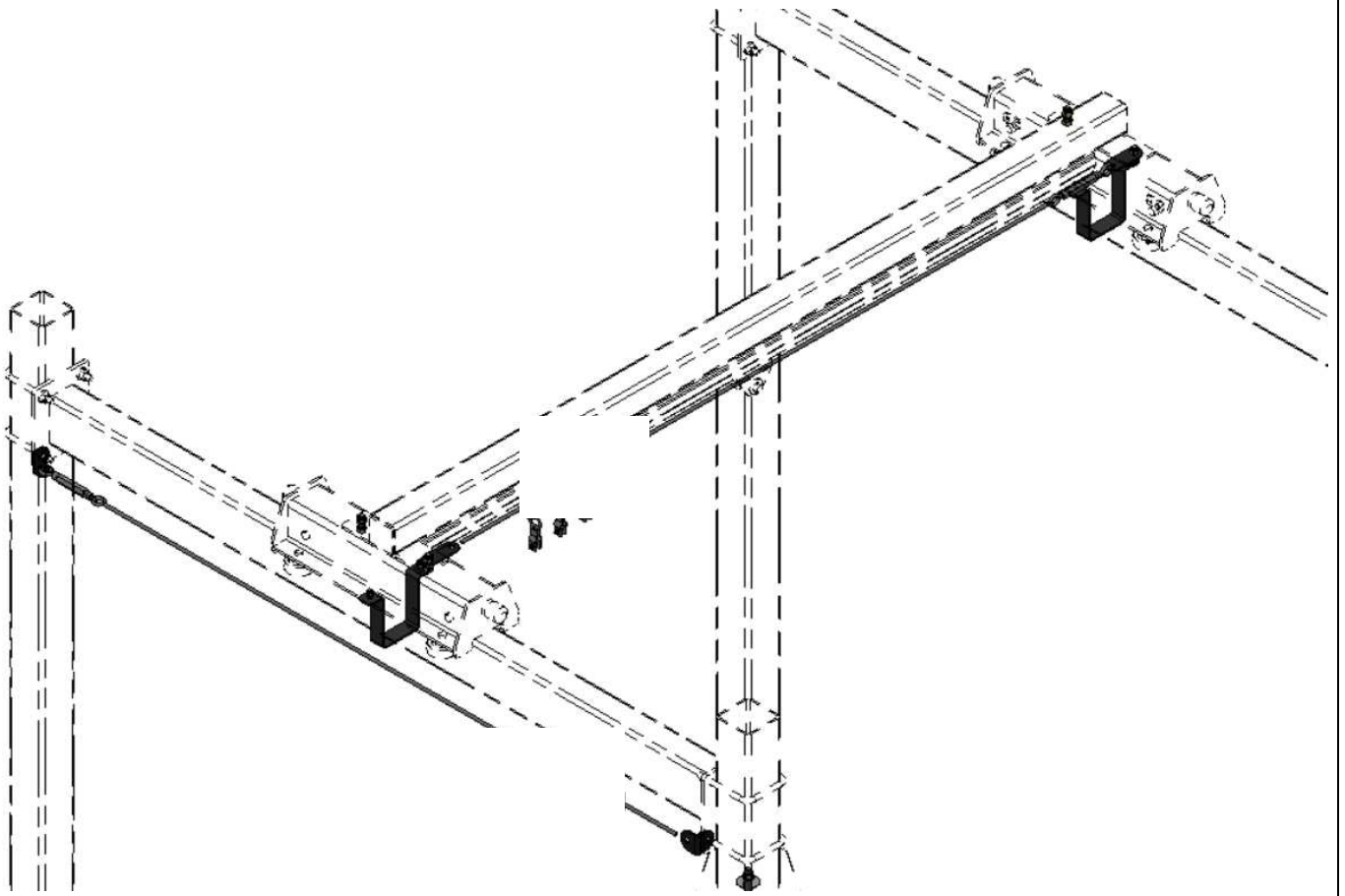

CRANE OPERATOR INSTRUCTIONS

PWI Overhead cranes and jib cranes generally handle materials over working areas where there are personnel. Therefore, it is important for the Crane Operator to be instructed in the use of the crane and to understand the severe consequences of careless operation.

It is not intended that these suggestions take precedence over existing plant safety rules and regulations or OSHA regulations. However, a thorough study of the following information should provide a better understanding of safe operation and afford a greater margin of safety for people and machinery on the plant floor. It must be recognized that these are suggestions for the Crane Operator's use. It is the responsibility of the owner to make personnel aware of all federal, state and local rules and codes, and to make certain operators are properly trained.

Qualifications

Crane operation, to be safe and efficient, requires skill: the exercise of extreme care and good judgement, alertness and concentration, and rigid adherence to proven safety rules and practices as outlined in applicable and current ANSI and OSHA safety standards. In general practice, no person should be permitted to operate a crane:

- Who cannot speak the appropriate language or read and understand the printed instructions.
- Who is not of legal age to operate this type of equipment.
- Whose hearing or eyesight is impaired (unless suitably corrected with good depth perception).
- Who may be suffering from heart or other ailments which might interfere with the operator's safe performance.
- Unless the operator has carefully read and studied this operation manual.
- Unless the operator has been properly instructed.
- Unless the operator has demonstrated his instructions through practical operation.
- Unless the operator is familiar with hitching equipment and safe hitching equipment practices.

Refer to the lifting (hoist) equipment's operating instructions.

Handling the Bridge Travel Motion

Before using the bridge of the crane, the operator should be sure the hook is high enough to clear any obstruction. Before a load is handled by the crane, the bridge should be put into position so that it is directly over the load. Start the load slowly and bring it up to speed gradually. Approaching the place where it is desired to stop the bridge, reduce the bridge speed.

Handling the Trolley Motion

Before a load is handled, the hoist should be positioned directly over the load that is to be handled. When the slack is taken out of the lifting chain, if the hoist is not directly over the load, bring it directly over the load before hoisting is continued. Failure to center the hoist over the load may cause the load to swing upon lifting. Always start the trolley motion slowly and reduce the trolley speed gradually.

Handling the Hoist Motion

Refer to the lifting (hoist) equipment operating instructions.

GENERAL SAFETY SUGGESTIONS

Know Your Crane

Crane operators should be familiar with the principal parts of a crane and have a thorough knowledge of crane control functions and movements. The crane operator should be required to know the location and proper operation of the main conductor disconnecting means for all power to the attachments on the crane.

Responsibility

Each crane operator should be held directly responsible for the safe operation of the crane. Whenever there is any doubt as to SAFETY, the crane operator should stop the crane and refuse to handle loads until: (1) safety has been assured or (2) the operator has been ordered to proceed by the supervisor, who then assumes all responsibility for the SAFETY of the lift.

Do not permit **ANYONE** to ride on the hook or a load.

Daily Inspection

Test the crane movement and any attachments on the crane at the beginning of each shift. Whenever the operator finds anything wrong or apparently wrong, the problem should be reported immediately to the proper supervisor and appropriate corrective action taken.

Operating Suggestions

One measure of a good crane operator is the smoothness of the crane operation. A good crane operator should know and follow these proven suggestions for safe, efficient crane handling.

1. The crane should be moved smoothly and gradually to avoid abrupt, jerky movements of the load. Slack must be removed from the sling and hoisting ropes before the load is lifted.
2. Center the crane over the load before starting the hoist to avoid swinging the load as the lift is started. Loads should not be swung by the crane to reach areas not under the crane.
3. Crane-hoisting ropes should be kept vertical. Cranes shall not be used for side pulls.
4. Be sure everyone in the immediate area is clear of the load and aware that a load is being moved.
5. Do not make lifts beyond the rated load capacity of the crane, sling chains, rope slings, etc.

6. Make certain that before moving the load, load slings, load chains, or other lifting devices are fully seated in the saddle of the hook with hook latch closed (if equipped with hook latch).
7. Check to be sure that the load and/or bottom block is lifted high enough to clear all obstructions when moving boom or trolley.
8. At no time should a load be left suspended from the crane unless the operator has the push button with the power on, and under this condition keep the load as close as possible to the floor to minimize the possibility of an injury if the load should drop. When the crane is holding a load, the crane operator should remain at the push button.
9. Do not lift loads with sling hooks hanging loose. If all sling hooks are not needed, they should be properly stored, or use a different sling.
10. All slings or cables should be removed from the crane hooks when not in use (dangling cables or hooks hung in sling rings can inadvertently snag other objects when the crane is moving).
11. Operators shall not carry loads and/or empty bottom blocks over personnel. Caution should be practiced when using magnet or vacuum devices. Loads, or parts of loads, held magnetically could drop. Failure of power to magnets or vacuum devices can result in dropping the load. Extra precautions should be exercised when handling molten metal in the proximity of personnel.
12. Whenever the operator leaves the crane, the following procedure should be followed:
 - Raise all hooks to an intermediate position.
 - Spot the crane at an approved designated location.
 - Place all controls in the "off" position.
 - Open the main switch to the "off" position.
 - Make visual check before leaving the crane.
13. In case of emergency or during inspection, repairing, cleaning or lubrication, a warning sign or signal should be displayed, and the main switch should be locked in the "off" position. This should be done whether the work is being done by the crane operator or by others.
14. Contact with rotation stops or trolley end stops shall be made with extreme caution. The operator should do so with particular care for the safety of persons below the crane, and only after making certain that any persons on the other cranes are aware of what is being done.

ANY SAFETY FEATURES AND MECHANISMS BUILT IN OR OTHERWISE PROVIDED WITH THE GARAGE SERIES CRANE BY PWI ARE REQUIRED FOR THE SAFE OPERATION OF THE CRANE. DO NOT, UNDER ANY CIRCUMSTANCES, REMOVE OR OTHERWISE IMPAIR OR DISABLE THE PROPER FUNCTIONING OF ANY CRANE SAFETY MECHANISMS OR FEATURES BUILT-IN OR OTHERWISE PROVIDED BY PWI FOR SAFE OPERATION OF THE CRANE. ANY REMOVAL, IMPAIRMENT OR DISABLING OF ANY SUCH SAFETY MECHANISMS OR FEATURES OR OTHER USE OR OPERATION OF THE CRANE WITHOUT THE COMPLETE AND PROPER FUNCTIONING OF ANY SUCH SAFETY MECHANISMS OR FEATURES AUTOMATICALLY AND IMMEDIATELY VOIDS ANY AND ALL EXPRESS AND IMPLIED WARRANTIES OF ANY KIND OR NATURE

LIMITED WARRANTY

STRUCTURAL: 3-Year (36 Month) Parts & Workmanship Warranty

Structural items include but are not limited to columns, headers, runways, and other stationary components of this PWI Ultra Lite System.

Unless otherwise specified, PWI guarantees that the structure or this product is free from material defects in design, materials, and workmanship under normal use, proper maintenance, and service. A corrosive or abrasive atmosphere is not to be considered a normal atmosphere.

This warranty is strictly limited to 36 months for single shift operation or 6,000 hours after installation, or 38 months after shipment, whichever is shorter. Within ten days after a defect is found, the warrantee must deliver a written notice to PWI. All requested warranty information must be received promptly by PWI in no more than 5 business days.

MECHANICAL: 1 Year (12 Month) Parts & Workmanship Warranty

Mechanical items include but are not limited to all types of Overhead Cranes, and other non-stationary PWI products that are designed for specific functional operation.

Unless otherwise specified, PWI guarantees that this mechanical product is free from material defects in design and workmanship under normal use, proper maintenance, and service.

This warranty is strictly limited to 12 months for single shift operation or 2,000 hours after installation, or 14 months after shipment, whichever is shorter. Within ten days after a defect is found, the warrantee must deliver a written notice to PWI. All requested warranty information must be received promptly by PWI in no more than 5 business days.

All standard non-engineered products including but not limited to hoists, trolleys, wheels, gearmotors, controls, and safety products, will fall under the default warranty of that specific manufacturer.

GENERAL:

This warranty will not apply to any product that has been repaired or altered outside of PWI manufacturing plant, or without specific instructions from PWI to make alterations. PWI will in no case allow or offer reimbursement for outside sources to perform repairs or make alterations to product in reference. If the product has (in PWI's judgment), had alterations made which adversely affect its serviceability or was subject to misuse, negligence, accident, or operated contrary to instructions or common practice, warranty shall be considered void.

Defective items will be repaired or replaced and returned to PWI at the cost of the owner. If PWI, at its discretion, finds the warranty claims to be justifiable, PWI will compensate by means of replacing or repairing faulty products or components free of charge. The sole liability of PWI for warranty claims is limited to those here. In no event will PWI be liable for damages in excess of the original sale price of the defective product, or for any consequential damages, nor will PWI be liable for any special or other work done unless specifically agreed to in writing. This warranty does not include or apply to fire, natural disasters, or other Acts of God.

Should the warrantee destroy, intentionally or not, any part of the warranted product, or any evidence concerning the origin of an alleged defect, or try to conceal evidence of causation, this warranty is cancelled, and warrantee will have no claim against PWI whatsoever.

This warranty does not cover coatings on any PWI products including paint, powder-coat, zinc, or galvanized coatings. Coating life can vary greatly based on the ambient environment your PWI product is installed in, which is simply out of the manufacturer's control. Touch-up painting or coating repair (after initial installation by PWI or customer) shall be the responsibility of the owner, unless specifically guaranteed in writing on project quotation.

Any interpretation of this warranty shall be done in the common pleas court in Indianapolis under Indiana law.

ALL OTHER REPRESENTATIONS, EXPRESS OR IMPLIED, WARRANTY, OR LIABILITY RELATING TO THE CONDITION OR USE OF THE PRODUCT ARE SPECIFICALLY, DISAVOWED, AND IN NO EVENT SHALL PWI BE LIABLE TO BUYER, OR ANY THIRD PARTY, FOR ANY DIRECT OR INDIRECT CONSEQUENTIAL OR INCIDENTAL DAMAGES

PERIODIC INSPECTION AND LUBRICATION RECOMMENDATIONS

The following is a checklist to be followed in performing periodic inspections and preventative maintenance on PWI Garage Series Systems. It is intended that this checklist be supplemented with any additional instruction sheets and maintenance manuals sent with each job.

The frequency of inspection and lubrication recommendations presented herein is based upon normal operating conditions of 10 complete Cycles per Day. If the actual duty cycle of a particular unit is greater or less than this, the inspections and lubrications should be performed more frequently or less frequently in proportion.

Each crane user has conditions peculiar to their needs, which may cause wear of certain parts. The tabulation given is only general and may be supplemented by an individual maintenance program to meet its own particular requirements. Particular attention should be given to corrosive conditions, excessive vibrations, extreme ambient temperature variations, and rough handling conditions.

Questions regarding damaged, worn, or cracked equipment components should be directed to the PWI National Sales Department at 574-646-2015.

The recommendations contained herein are to be supplemented by any vendor instructions, which are included in this manual.

WARNING: Power should be off and locked when performing maintenance on any part of the system.

* State and local codes may require inspection and maintenance checks more often. Please check the state and local code manuals in your area.

RUNWAYS & SUPPORT STEEL

Item	Component	Maintenance	Frequency
1	Column Hardware	Check for loose or cracked bolts & hardware. Check for full compression of lock washer (if applicable). Bolt should be tightened to manufacturer's specifications.	Once per Year
2	Runway Hardware	Check for loose or cracked bolts. Check for full compression of lock washer.	Once per Year
3	Bridge Hardware	Check for loose or cracked bolts and hardware.	Every 6 months
4	Runways	Check for runway wear or damage. Clean surface of Runway of build up if necessary.	Every 6 months

NOTES:
