

GANTRY QUANTITY : 1
GANTRY CAPACITY : 2 Ton
HOIST QTY : 1
HOIST TYPE : Electric Chain Hoist
HOIST CAPACITY : 2 Tons
HOIST BRAND : Starke STK
HOIST MODEL : STK2026-20
HOIST VOLTAGE : 480v Three Phase
TROLLEY MODEL : Starke SPT200L
HEADROOM : 25.65"

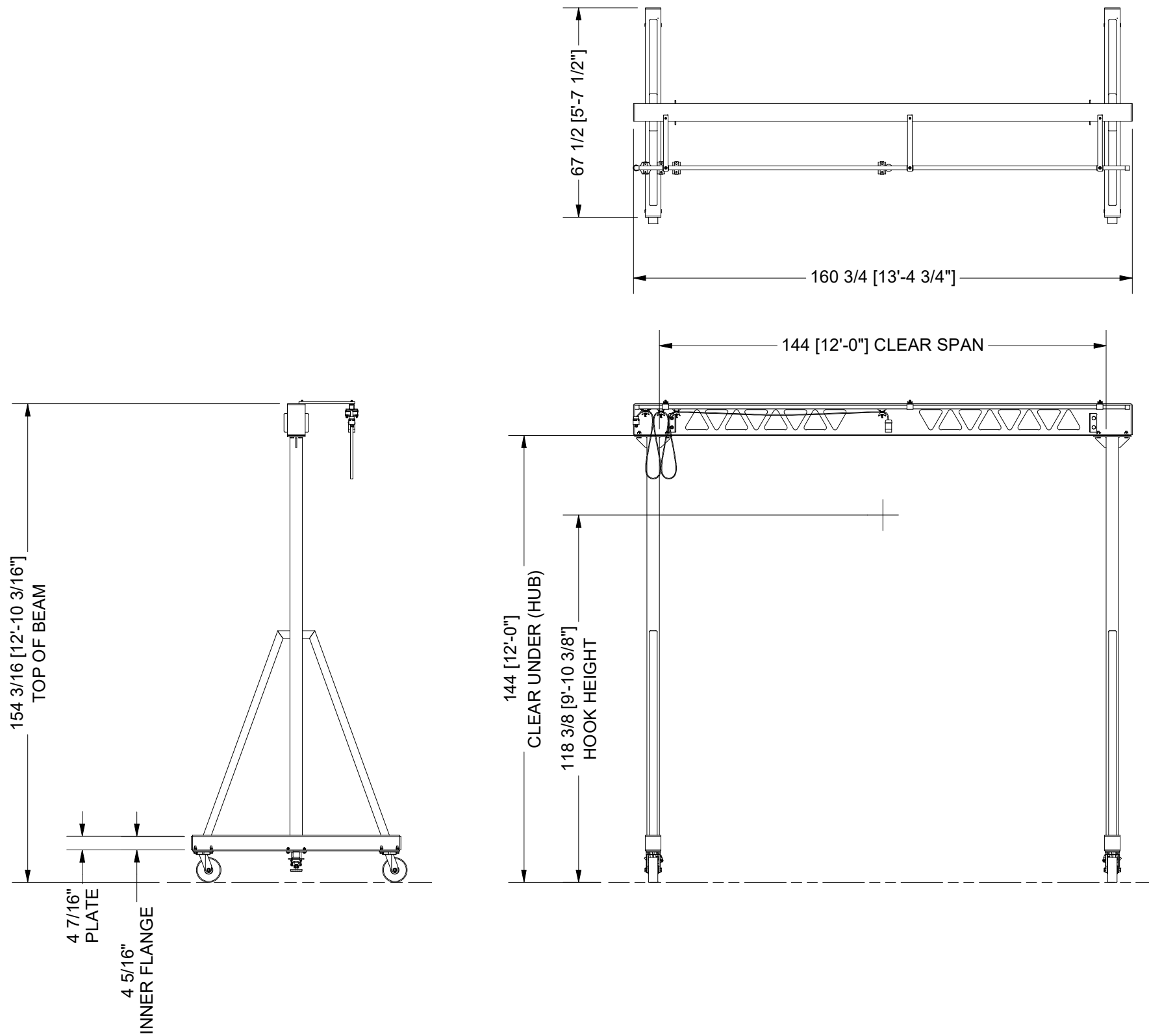

***QTY: 1**

SUBMITTAL REVIEW
 CUSTOMER IS RESPONSIBLE TO VERIFY ALL DIMENSIONS.
 SIGNED APPROVAL AUTHORIZES PWI TO PROCEED WITH
 SHOP FABRICATION AND INSTALLATION.
 APPROVED
 APPROVED WITH CHANGES NOTED
 SIGN ABOVE _____ DATE _____

GC #21707 - GCU version 240605.4

JOB:
 HOIST ZONE CUSTOMER
 SAMPLE APPROVAL DRAWING
 (PWIG-UL-FH-40001212)
 Quote

DRAWING:
 Ultra Lite Hixed Height Gantry Crane
 GC #21707

PAINT COLOR: PAINT YELLOW		
SALESMAN: HOIST ZONE SALESMAN	TOLERANCES (U.N.O.): DIMENSIONS: ±1/8" ANGLES: ± 0.2°	

NOTE: SHIPS PARTIALLY ASSEMBLED

SHIPPING LIST

ITEM	QTY	PART NO.	DESCRIPTION	LENGTH	UNIT WT.	NET WT.	FINISH
1	4	PL1019	6 X 4 END STOP	6 in	2.90	11.62	BLACK PDC
2	4	57DS80LR2419YY	8X3 SWIVEL CASTER, DUCTILE, 6000# CAP		31.73	126.92	PURCHASED
3	2	FL-ADJ-810	ADJUSTABLE FLOOR LOCK	7 in	8.00	16	PURCHASED
4	1	-	GANTRY BEAM WELDMENT		274.11	274.11	PAINT YELLOW
5	2	-	LEG WELDMENT		300.50	600.99	PAINT YELLOW
6	16	-	1/2"-13 HEX BOLT (GR. 5)	2 in	0.02	0.33	ZINC
7	16	-	1/2" FLAT WASHER (ASME)		0.00	0.08	ZINC
8	16	-	1/2"-13 NYLON LOCKING NUT (GR. 5)		0.01	0.1	ZINC
9	11	-	3/8"-16 HEX BOLT (GR. 5)	1 1/2 in	0.01	0.09	ZINC
10	8	-	3/8" FLAT WASHER (ASME)		0.00	0.02	ZINC
11	8	-	3/8"-16 NYLON LOCKING NUT (GR. 5)		0.00	0.02	ZINC
12	3	-	3/8"-16 NYLON LOCKING NUT (GR. 8)		0.00	0.01	YELLOW ZINC
13	8	-	5/8"-11 STRUCTURAL BOLT (A325)	1 3/4 in	0.03	0.26	BLACK OXIDE
14	4	-	5/8"-11 STRUCTURAL BOLT (A325)	2 in	0.04	0.14	BLACK OXIDE
15	8	-	5/8"-11 HEAVY HEX NUT (A563)		0.01	0.12	BLACK OXIDE
16	4	-	5/8"-11 NYLON LOCKING NUT (GR. 8)		0.01	0.05	YELLOW ZINC
						TOTAL WT.#	1074.47

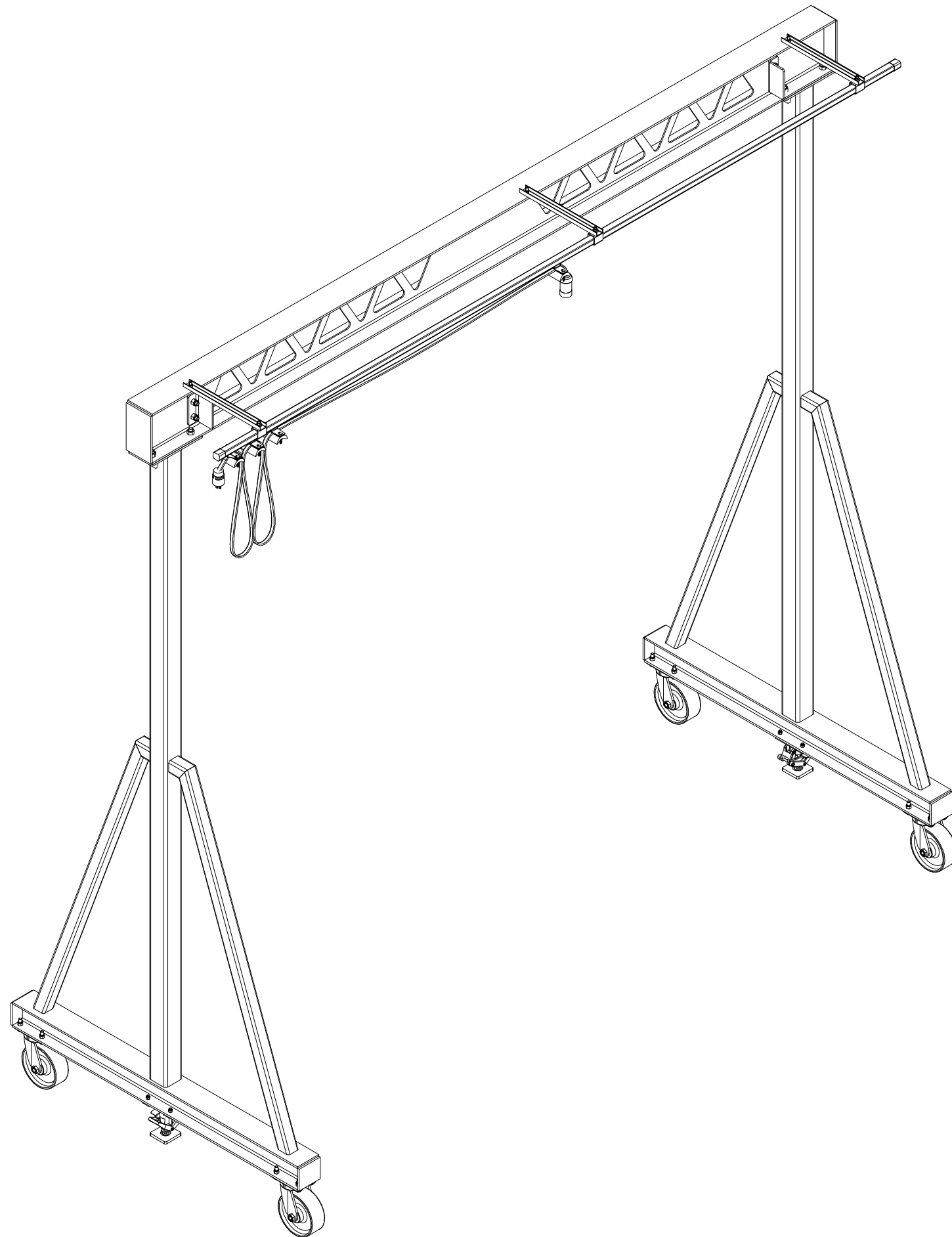

GANTRY CAPACITY: 2 Ton
HOIST TYPE: Electric Chain Hoist
HOIST CAPACITY: 2 Tons
HOIST BRAND : Starke STK
HOIST MODEL: STK2026-20
HOIST VOLTAGE: 480v Three Phase
TROLLEY MODEL: Starke SPT200L

***QTY: 1**

PAINT COLOR: PAINT YELLOW		
SALESMAN: HOIST ZONE SALESMAN		
<small>TOLERANCES (U.N.O.): DIMENSIONS: ±1/8" ANGLES: ± 0.2°</small>		

JOB: HOIST ZONE CUSTOMER SAMPLE APPROVAL DRAWING (PWIG-UL-FH-40001212) Quote	DRAWING: Ultra Lite Hixed Height Gantry Crane GC #21707
--	---

GC #21707 - GCU version 240605.4

Y:\Automated Drawings\GC #21707\GC #21707 - Customer Approval Drawing.pdf 2024-06-05 11:41