



OWNER'S MANUAL

Festoon Style Crane Kit

Assembly Instruction Manual

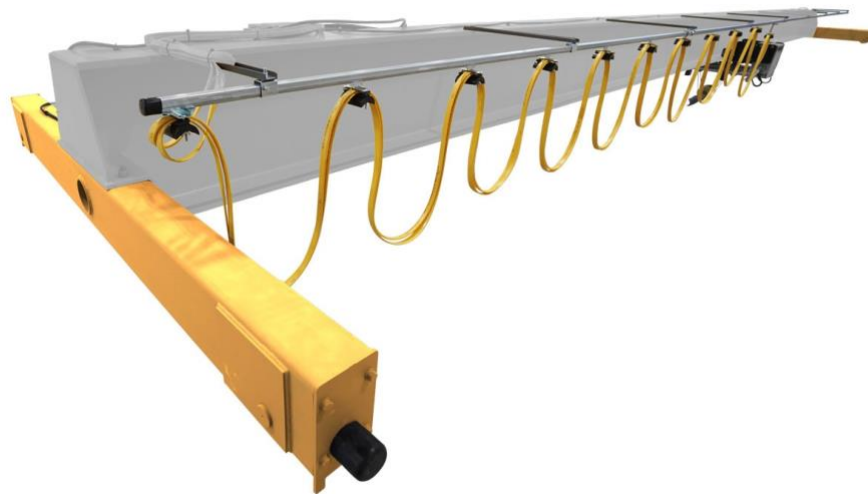

Table of Contents

1.0 Safety	3
2.0 Components List.....	4
3.0 Other Components	4
4.0 Installation Instructions	5
4.1 Tools Required	5
4.2 Installing End Trucks	6
4.3 Festoon Brackets	7
4.3.1 Festoon Bracket Sizes	7
4.4 Paint	8
4.5 Panel Bracket Installation	9
4.6 End Truck Motor Installations	10
4.6.1 Geared End truck Motor Installation (STT Model End Trucks).....	10
4.6.3 Geared End truck Motor Installation (SCU Model End Trucks).....	11
4.7 Installing the Wire Rope Hoist with Integrated Trolley.....	12
4.8 (Alternative) Installing Chain Hoist Trolleys	13
4.9 Installing Chain Hoists	14
4.10 Installing Festoon Track and Festoon.....	15
4.11 Fabricating and Installing the Festoon Tow Bracket.....	16
4.12 Connecting cables, cable management and strobe light connection.	17
4.12.2 Installing the Strobe Light	17
4.13 Installing End Stops	18
4.14 Testing the Crane	19
5.0 Troubleshooting	20
5.1 Diagnostics	20
6.0 Fastener Torque Specifications	21
7.0 Appendix A	22
7.1 Wiring Information	22
Starke Products Warranty.....	23

1.0 Safety

Safety comes first when assembling your Starke Crane Kit. For some items, proper tools and lifting equipment are necessary. Please be sure to select appropriate equipment to move or install heavy items. A forklift is highly recommended when installing – End-trucks, motors, the control panel, and the hoist/trolley.

To maximize efficiency, it is recommended that you install the electrical and test the crane before installing the bridge. Doing so will reduce the risk of falling items, and testing faults. When setting up your work area, make sure the crane is set on stands that are built heavy enough to support the weight. Since it is necessary to access the bottom of the end-trucks, it is not recommended to support the crane from the end-trucks when installing components.

OSHA requires that you lock out and tag out the crane system before installation of another crane, service, or any arial work performed around a crane system.

Listed below are the components included in your kit. You should also have a packing slip with the correct quantities of all items. Please verify that everything has arrived before beginning assembly.

2.0 Components List

- (1) Starke SCP control panel (warning strobe light shipped inside enclosure).
- (1) Starke control panel mounting bracket.
- (1) Control panel mounting hardware kit.
- (2) End trucks, bolt on style with plates (both left and right configurations).
- (2) End truck motor assemblies.
- (1) End truck bolt kit.
- (4) Rubber end-stop bumpers for end trucks.
- (2) Sets of clamp-on end stops.
- (1) Hoist and trolley assembly.
- (2) Motor lead sets, plug and play (one long & one short).
- (1) Power feed wire, plug and play connection to hardwire.
- (1) Festoon wire kit, plug and play.
- (1) Festoon track kit.
- (1) Cable management kit.
- (1) Pillow block bearing and gear assembly. (SCU end trucks only).

3.0 Other Components

Due to the unique designs of each crane system, you will need to provide your own materials for these components:

- Festoon track mounting brackets.
- Tow bar to tow festoon cable.
- Gear lubricant (grease gun required on SCT Model End Trucks)
- Paint

4.0 Installation Instructions

4.1 Tools Required

- Torque wrench capable of 400 ft lbs.
- 9/16" combination wrench and socket wrench (with 1 ft extension).
- 3/4" combination wrench and socket wrench.
- 15/16" combination wrench and socket wrench.
- 3/8" combination wrench or socket wrench.
- 18mm combination wrench. (Qty. 2)
- 21mm combination wrench for (STT-250 End Trucks)
- 13mm combination wrench (STT-170 End Trucks)
- 6mm Allen wrench (STT-250 End Trucks)
- #2 Philips screwdriver.
- Precision screwdriver set.
- 1 1/4" combination wrench and socket (Use with torque wrench).
- 1/4" Hex Impact driver. (8mm socket driver included in kit)
- 1/2" Drill and drill index including 1/4" and 9/16" bit. (1/8" needed for SCT end-trucks)
- 1/2" impact wrench med/high torque and impact sockets up to 1 1/4" size.
- Welder
- Large framing square.
- Tape measure(s).
- Hammer(s).
- Misc electrical tools.
- Steel cutting tool (saw or grinder)
- Heavy duty saw horses, or similar items
- Forklift or overhead crane

Other tools and equipment may be used to make the assembly process faster.

4.2 Installing End Trucks

Tools Required: tape measure, framing square, large torque wrench with 1 ¼ socket, 1 ¼ combination wrench for STT style(15/16 for SCT), and a welder of your choice.

A 1/8" tolerance is required when aligning end trucks.

Use a framing square to achieve proper end-truck to girder alignment. After squaring Your end-trucks to your bridge girder, measure diagonally to confirm everything is square. If using the supplied plates, it is allowable to equally shim one side of the end-truck to achieve tolerance. DO NOT remove and reinstall bolts that have been

If using the supplied End-Truck plates, next torque down all end truck fasteners. (refer to torque specifications chart)



4.2.1 SCU Style End Truck



4.2.2 STT Style End Truck

4.3 Festoon Brackets (this can be done after Step 3: Paint, if desired)

Tools required: 9/16” socket wrench, welder, or bolt on bracket components with correct tools, tape measure.

Determine the length of festoon bracket required for your crane. The brackets can be either welded on or bolted on, depending on your preference. Drill a 7/16” hole, 1” from the end of the bracket to attach to the bridge beam. See table below for bracket length recommendations.

▲ IMPORTANT NOTE: Bracket lengths below are suggestions. A 3” minimum clearance from festoon track to hoist is necessary for optimal performance. When installing brackets, make sure to double check measurements.

(Length is measured from edge of beam flange to end of bracket)

Type (Starke)	Capacity	Without pendant station	With pendant station
Chain Hoist	1/8 Ton to 1 Ton	14”	19”
Chain hoist	2 Ton to 5 Ton	16”	21”
Wire Rope	3 Ton	26”	31”
Wire rope	5 Ton	26”	31”
Wire rope	7.5 Ton to 10 Ton	28”	33”
Customer Provided	Any	Custom	Custom

4.3.1 Festoon Bracket Sizes

For independent pendant traveler stations, we recommend spacing festoon tracks 5” apart center to center.

The recommended distance between brackets is 79” This is to accommodate the 13’ track sections.

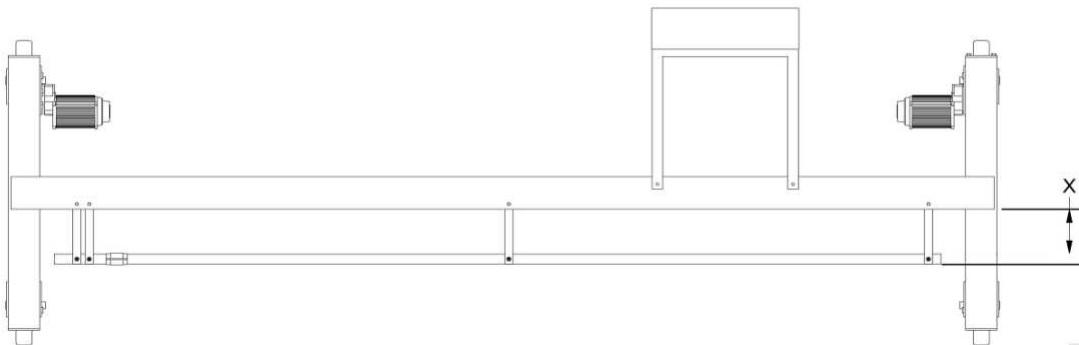

4.4 Paint

Tools required: paint, and painting equipment

When painting the crane, it is HIGHLY recommended to tape off a 1.5-2" section where the trolley wheels run. This will help the trolley roll smoother, and will keep paint scrape from building up, creating lumps for the wheels to drive over.

It is also recommended to tape or plug the threaded holes where the end-truck motor mounts, to make installing the motor hardware easier.



4.4.1 Taped Off Section on Crane

4.5 Panel Bracket Installation

Tools required: drill with 9/16" bit, 3/4" wrench and socket wrench, 9/16" wrench and socket wrench, steel cutting tool.

▲ IMPORTANT NOTE: use provided panel mounting hardware kit

We recommend mounting the bracket on the right side of the crane (when facing the panel). Refer to the print below.

Determine the length of bracket needed for the control panel. A **3" clearance** is recommended between the bracket and the hoist (see chart below for estimated minimum length requirements). Generally, with wire rope hoists leave the bracket full length, and install 2 inches onto the beam flange. With chain hoists, the bracket can be cut down to the correct length or left full length. If you are unsure about how much clearance you will have, you can mount the hoist and trolley first to determine the length of bracket needed. The location of the bracket is to be **5' from the center of the End Truck to center of the panel.**

Drill two 9/16" holes in the beam flange to fasten the panel. It can either be fastened to the top of the top flange, or the bottom of the top flange. Use the provided hardware (1/2 grade 8 fasteners) to install the bracket. You can also install the panel at this point, using the 3/8x3.5 inch grade 5 bolts. Washers are necessary on the inside of the panel only

▲ IMPORTANT NOTE: when installing the panel bracket on the bottom of the top flange, a MINIMUM of 2" of bracket on the beam flange is REQUIRED.

Type (Starke)	Capacity	Beam to Bracket Length
Chain Hoist	1/8 Ton to 1 Ton	13.5"
Chain Hoist	2 Ton to 5 Ton	14.5"
Wire Rope Hoist	3 Ton to 5 Ton	21.5"
Wire Rope Hoist	10 Ton	27.5"
Other	Any	Custom

4.5.1 Panel Bracket Sizing

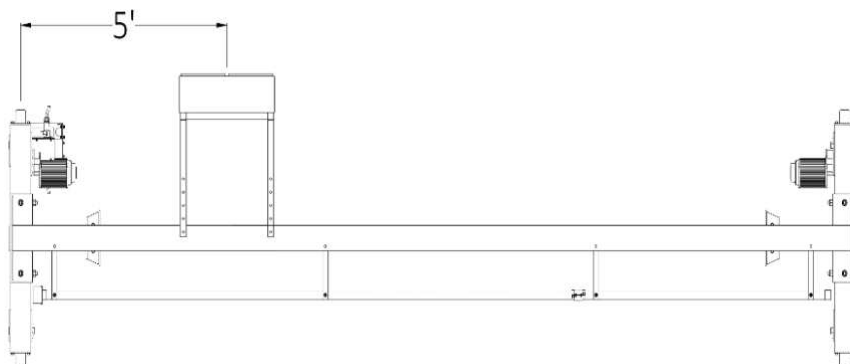
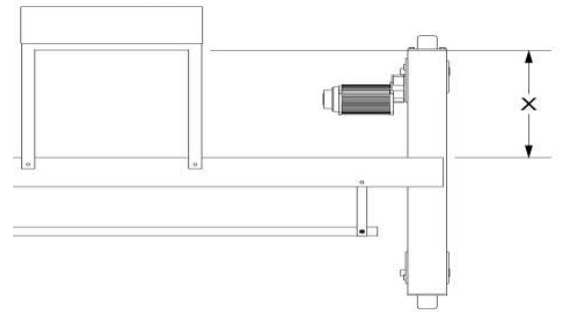

4.6 End Truck Motor Installations

4.6.1 Geared End truck Motor Installation (STT Model End Trucks)

Tools required: 18mm combination wrench, (21mm for STT-250 end trucks) 13mm combination wrench (6mm allen for STT-250 end-trucks), and grease.

For top running rail type end trucks, Installing the geared motor on a 5-ton to 10-ton system will require the gear to be removed. Refer to the steps below. Do not fully bolt in the end truck motor before re-installing the gear. When you re-install the gear, Install the gear **FIRST**, integrated collar facing the motor. Next install the spacing collar, followed by the washer and bolt assembly. Check to make sure the gears properly mesh. Use thread locker on the bolt/ lock washer on the gear keeper bolt. Thread locker is provided in the cable management kit for your convenience. Verify that the gears mesh properly. Lubricate the gears using an open gear lubricant.

4.6.2 Remove Gear



4.6.3 Install Gear (Use Loctite)



4.6.4 Install Hardware

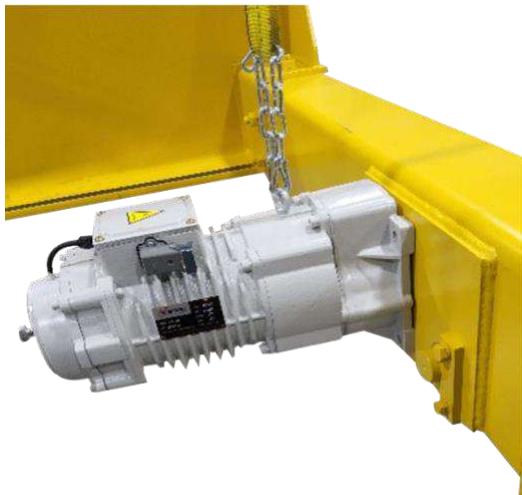

4.6.5 Tighten Fasteners (See Torque Spec. Chart)

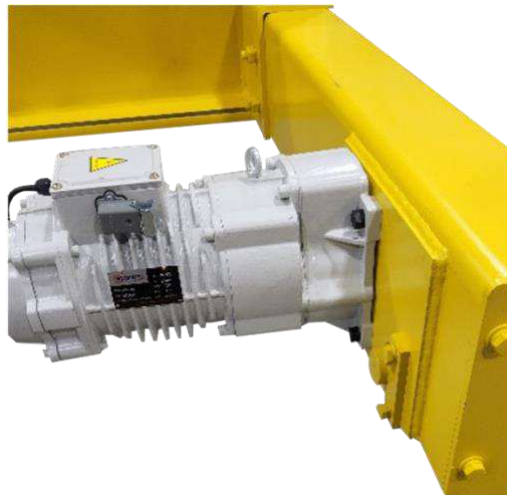

4.6.3 Geared End truck Motor Installation (SCU Model End Trucks)

Install the geared motor and torque fasteners.

Next install the pillow block and gear assembly. Be sure to use the provided wedge washers on the angled part of the end truck, and regular washers on the pillow block itself. Before tightening, make sure gears mesh properly.

▲IMPORTANT NOTE: Tightening without gears meshing may break the pillow block assembly. Do not overtighten. The pillow block may not be square to the end truck gear yet. The pillow block may not be square to the end truck gear yet.

Use the provided hex shaft as a lever to align the gears towards each other. Install the hex shaft. At this point, Check the gear lash. If the gears are tight, use the provided shims to loosen the gears. The gear should not be tight, there should be a small amount of gear lash.

▲IMPORTANT NOTE: Tightening without gears meshing may break the pillow block assembly. Do not overtighten. The pillow block may not be square to the end truck gear yet.

After an acceptable lash is achieved, trim one end of the hex shaft to the proper length (1/2" longer than the gear assembly width) and reinstall the shaft. Next drill a 1/8 hole and install the keeper roll pin.

Lubricate the gears using an open gear lubricant, and pillow block bearing assembly using a grease gun.

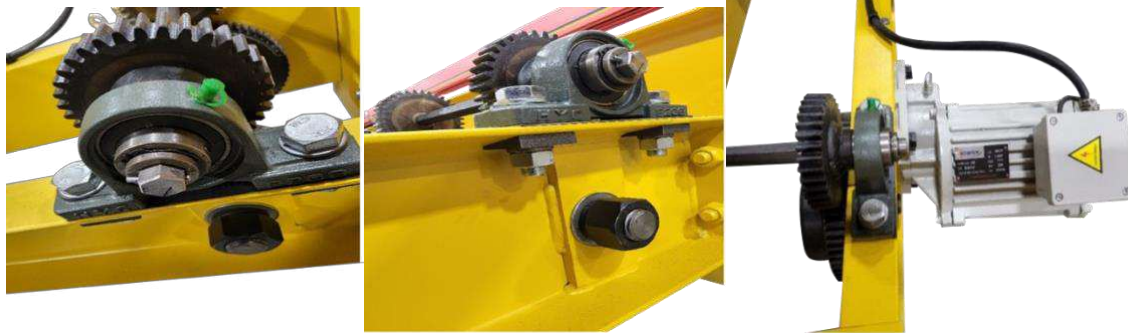

4.6.4 Gears

4.7 Installing the Wire Rope Hoist with Integrated Trolley

Tools required: proper size wrench of your choice

Begin by opening the trolley up wide enough to fit over the flange of the girder. To adjust the trolley size, first loosen the locking collar on the hex shaped wheel driveshaft (if equipped) then use the adjusting nuts to widen or narrow the trolley size.

▲IMPORTANT NOTE: Adjust both nuts evenly to prevent binding!

It can be helpful to grease the shaft that holds both sides of the hoist together. After adjusting the trolley to fit the beam, raise the trolley up to where the wheel height is above the bottom beam flange. Do not raise the hoist/trolley too high otherwise it will bind against the beam. This may cause binding issues! Use the adjusting nuts to draw the trolley back together onto the beam flange. The width of the trolley should be about 1/16 larger than the beam flange. To check this, after the trolley is set and the lifting platform/skit is removed, pull the hoist to one side, and measure/estimate the wheel to flange gap.

▲IMPORTANT NOTE: It is imperative that the flange to wheel gap is the same on both sides. Failure to properly adjust wheel to flange gap will cause premature wheel wear.

After the wheel to flange width is properly set, make sure to lock the driveshaft collar in place (if equipped) and tighten down ALL locking nuts.

▲IMPORTANT NOTE: Failure to tighten all fasteners could result in injury or death

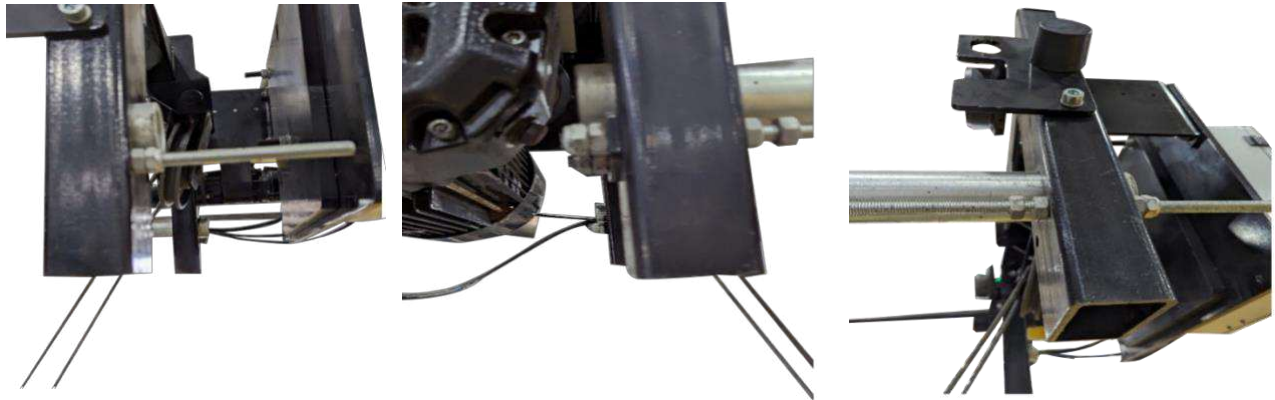

4.7.1 Fasteners on Driveshaft Collar

4.8 (Alternative) Installing Chain Hoist Trolleys

Tools Required: tape measure.

▲IMPORTANT NOTE: installing the trolley before the crane is set is highly recommended

First remove the pin holding the trolley together. Next, determine the spacing that your trolley is to be set at. The spacing should be 1/16" to 3/16" wider than your beam flange (measure from the side guide wheels on the trolley). Use the provided spacers to center the Hoist mounting lug in the center of the trolley. If the trolley cannot go wide enough for the flange, but is within one inch, remove the shaft bolt on the motor side, and move the shaft out one inch. If the trolley does not go wide enough even with the added spacing, contact your sales rep to order a "Trolley flange width adder".

▲IMPORTANT NOTE: when installing a 5-ton trolley, make sure the secondary chain mount is facing the correct direction (right)

Install the trolley onto the beam, panel end facing the festoon and double check spacing.

▲IMPORTANT NOTE: failure to properly secure the cotter key could result in injury or death.

Check for manufacturer defects when installing and bending the cotter key.

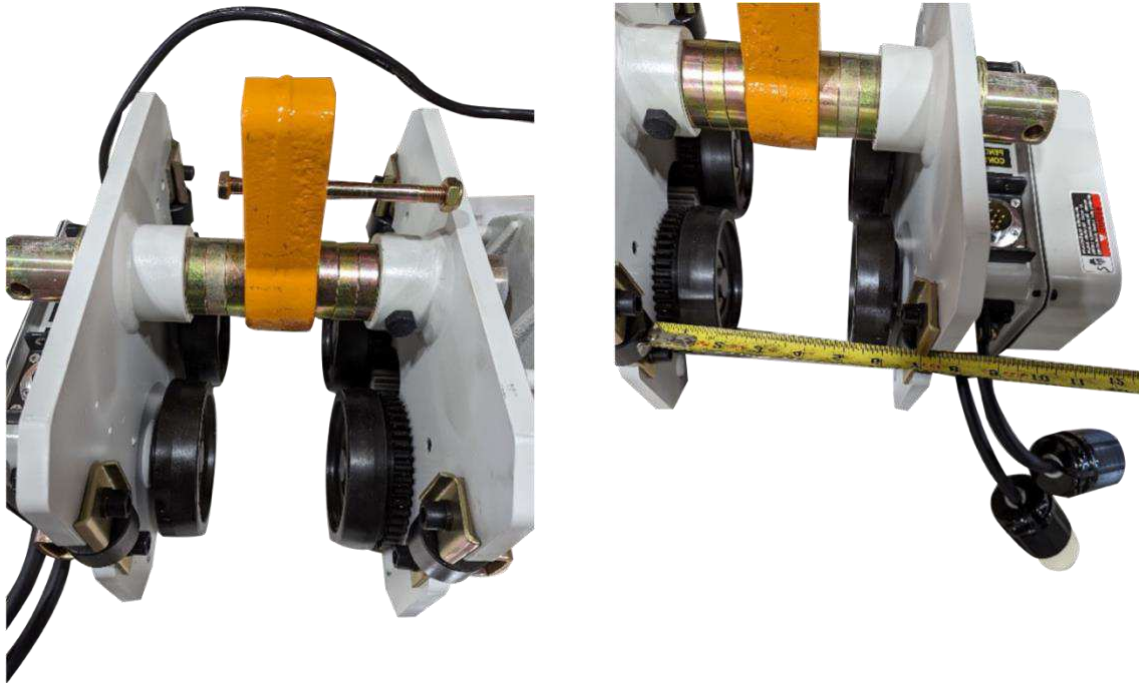

4.8.1 Spacing of Trolley

4.9 Installing Chain Hoists (Skip if Wire Rope Hoist is Used)

▲IMPORTANT NOTE: this step can be done after the bridge is installed

tools required: 18mm combination wrenches.

Remove the top pin from the hoist. Next hang the hoist, the panel side facing the festoon, and install the pin and cotter key. An anti-sway bolt is provided with the trolley to ensure minimal sway.

▲IMPORTANT NOTE: failure to properly secure the cotter key could result in injury or death.

▲IMPORTANT NOTE: check for manufacturer defects when installing and bending the cotter key.

Check for manufacturer defects when installing and bending the cotter key.

Install the chain bag using the supplied hardware mounted on the hoist. You may have to pull the chain bag mounts into place to install.

Connect the patch cable to the hoist and tighten the retaining nut.

Connect the other end into the trolley (connect with hoist plug) and tighten the retaining nut. Next, connect the hoist power cord to the female power drop from the trolley.

After all cables are connected, you will need to fabricate, and install a festoon tow bracket to minimize drag on the festoon. This Helps maximize the life of the festoon. (see page 18)



4.9.1 Hoist Plug

4.10 Installing Festoon Track and Festoon.

Tools required: 10mm combination wrench, 9/16 combination wrench. Tow arm components

Begin installing the track hangers onto the festoon brackets. (see page 9 for festoon bracket details). Start on the end of the bridge with the panel. Place the track hanger with side bolt first. Next, begin installing the festoon track into the hangers. If the track binds in the hangers, the hangers can be bent slightly to allow a tight slip fit. Install splice couplers as needed between the tracks.

▲IMPORTANT NOTE: top bolts are clamping bolts. Side bolts are alignment bolts. Do not tighten side alignment bolts all the way! Doing so will restrict festoon trolley motion.

Alignment bolts are made to line up closely. Perfect alignment may not be achievable. Refer to the photos below to see acceptable alignment. You can test the quality of the alignment by sliding a festoon trolley through the track, and checking if it binds or catches over the splices.

Next, install the festoon wire clamping trolley (Shown below) at the start of the festoon track, the same side as the hanger bolt is mounted on (see picture 3). Install festoon trolleys and space to approximately 5 ft between trolleys. Due to Starke festoon kits coming with quick disconnect plugs, you will need to remove the plastic saddles on the festoon trolleys to install the cable. Adjust trolley distance as needed. The last trolley installed closest to the hoist, should be the festoon tow trolley (sample picture 4 below).



4.10.1 Festoon Components

4.11 Fabricating and Installing the Festoon Tow Bracket

Due to differing beam sizes and widths, you will need to fabricate a custom festoon tow bracket. A steel tube is recommended for this, but not required. Pictured below is an example of a custom adjustable bracket that we created. Adjustable brackets are not required, but are recommended in most cases.

▲IMPORTANT NOTE: The festoon tow bracket needs to be mounted as far from the start of the festoon as possible to prevent festoon stack up issues. The photo below pictures the festoon starting from the right. If you mounted the panel according to the suggested print (see page 11), the festoon will start from the left and the tow bracket should be mounted on the right side of the hoist, opposite of what the picture shows.

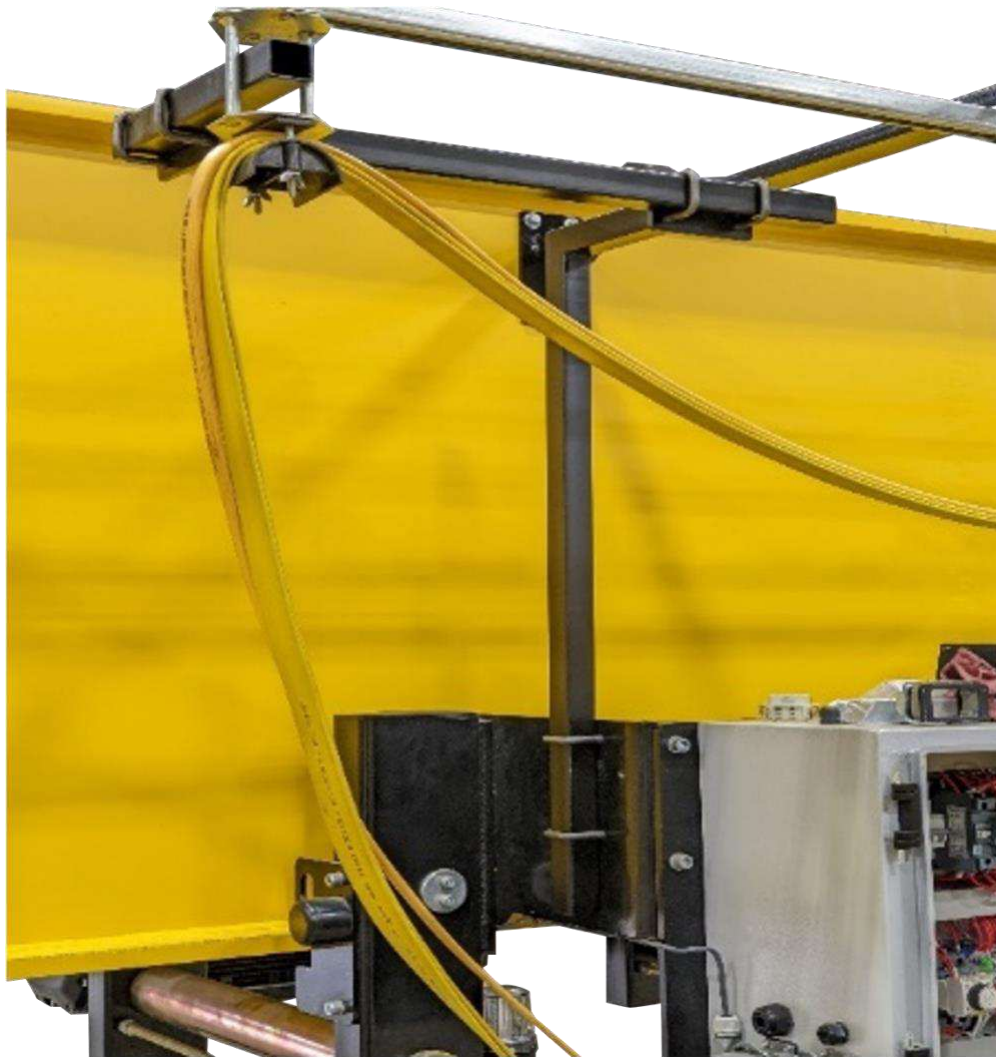

4.11.1 Festoon Tow Bracket

4.12 Connecting cables, cable management and strobe light connection.

Tools required: drill with 1/4" bit, #2 Phillips, 3/8" combination wrench.

Install the cables for the end trucks. It does not matter which cable goes to panel plug A or panel plug B at this time. We recommend mounting the cables on top of the crane and using the adhesive tie mounts to secure them down. Adhesive tie mounts and zip ties are found in your cable management kit.

For the festoon, footman clips are available to secure the festoon. Use a drill to create anchor holes for the footman loops. Zip ties are also available to secure cables to the panel bracket.

▲IMPORTANT NOTE: when installing adhesive tie mounts, clean the surface that you are placing the pad on first, then install the pads.



14.12.1 Cable Management

4.12.2 Installing the Strobe Light

After all cables are installed, install the strobe light into the bottom of the panel. Inside the panel there is a power plug that will connect to the strobe light. The strobe light will only flash when the bridge is in motion.

4.13 Installing End Stops

Tools required: 15/16 combination wrenches.

Refer to the photos below for proper installation of end stops.

It is recommended to cut the threaded rod to the width of your crane. End stops should be placed so that you have a minimum distance of 3 inches between the hoist/trolley and any other item that it could hit.

▲ IMPORTANT NOTE: The stack up of festoon can also affect the end stop placement. Do not place the end-stop too close to the end-truck to where the festoon pulls too tight.

Tighten the end stop bolts first, then tighten the threaded rod. This will ensure that the end stop stays straight and has maximum contact on the beam. After everything is hand tight, torque to spec.

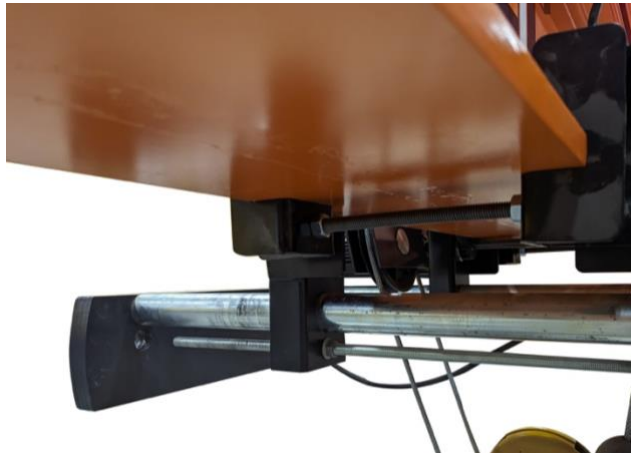

4.13.1 End Stops

4.14 Testing the Crane

Tools required: miscellaneous electrical tools.

▲ IMPORTANT NOTE: to ensure everyone's safety, testing is to be done by a qualified electrician. It is recommended that you test the crane before installing onto your runway.

After all plugs are connected, Install the power wire and connect to your building power.

All crane systems are required to have a safety disconnect clearly marked to ensure easy shut-down in case of emergency.

▲ IMPORTANT NOTE: due to the crane being controlled using a Variable Frequency Drive, it can be tested, but generally will not run well on generator power.

Once you have the correct power connected to your crane, you can begin testing. If the bridge runs backwards, swap the motor plugs (a and b) on the control panel. If the trolley moves backwards, you will need to swap the two red wires on the relays mounted on the panel door labeled T FWD and T REV. If the hoist (can be tested later if installing with the crane set on the runways) does not move up and down, or makes a clicking sound while not running, swap the hoist power plug wires (black and red) or the main incoming power phases. Swapping the main input phases will not affect bridge or trolley motion. If there are other issues present, contact your dealer for technical support.

After the crane is tested, double check that all bearings, and gears that can be greased, have been greased. It is important that you check all hoisting components for proper lubrication. Refer to the component's manual specifications for additional details.

For Grounded B phase systems, the grounded phase must be line 2. (white) double check that the grounded leg is not on the control transformer input power. If the grounded phase is on lines 1, or 3, the control transformer will not supply the proper control power, and the control circuit will not run.

5.0 Troubleshooting

5.1 Diagnostics

Relays in panel click but end truck motors don't run.

Check to make sure the drive displays a frequency number if not...

- Lcp is on off/reset
- Drive isn't programmed (call customer support)
- Lost control to drive. Check control wires(on drive connections, test DC between #20 and the 3 inputs (18,19,27))

Drive displays a frequency number, but crane doesn't move

- Check input power
- Check power to the drive
- Make sure brake contactor pulls in when a motion button is pressed

Motors not in sync

- Make sure all wires are tight from drive to motor connections
- Check braking system, can you hear each end truck brake "click"
- Ohm motor connections*****
- Last option on new cranes only! Check center to center of end trucks.

Motors run in opposite directions

- Contact your dealer for help regarding switching motor phasing

Relays in panel don't turn on at all

- Check radio or pendant connections
- Test power to relays and find where signal power is lost (check between top terminal #1 and input power to the terminal strips, then directly on the signal coil on the relays)

Crane won't turn on at all

- Check control fuse (light on holder should illuminate if the fuse is blown)
- Check for a green light on the radio, if no light check power between x1 and x2 (see schematics)
 - If no power is found, check input power to transformer and output power before the fuse. CHECK FOR GROUNDED B PHASE BEFORE REPLACING TRANSFORMER
- If radio functions check for power between x2 and MLC terminal, followed by checking power directly on main line contactor signal (A1 & A2)

Hoist Clicks or doesn't run

- Swap phasing on the hoist.
- Make sure all plugs are connected.
- Make sure limit switch is not stuck
- Test power at hoist plug. (Refer to appendix A)

6.0 Fastener Torque Specifications

Bolt Type	Torque Spec.
M6 8.8 (gear retainer)	84 IN/LB (10.5 NM)
M12 8.8 (motor mount)	75 FT/LB (101 NM)
M16 10.9 (Pillow Block)	55 FT/LB (27 NM) over torque can break bearing mounts
10-32 GR2 (footman loop)	31 IN/LB (hand tight)
3/8 GR5 (panel mount)	36 FT/LB (49 NM)
1/2 GR8 (panel bracket)	Up to 120 FT/LB (162 NM)
5/8 GR5	170 FT/LB (230 NM)
3/4 A325 (End trucks)	Dry 350 to 425 FT/LB Oiled 260 to 320 FT/LB

7.0 Appendix A

7.1 Wiring Information

Plug pin-out

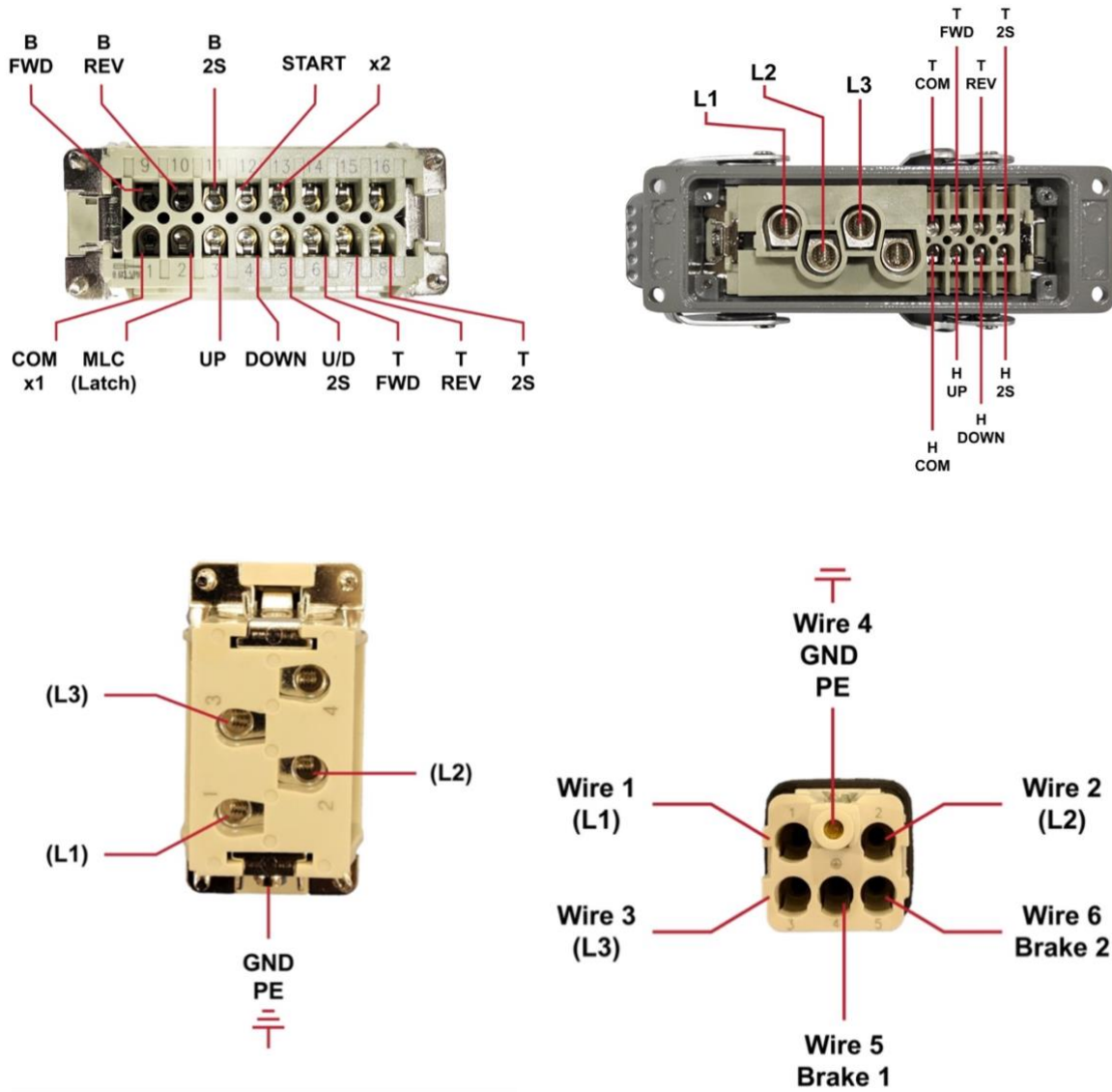

Panel and Hoist wiring found with those products.



Starke Products Warranty 1 Year (12 Month) Parts & Labor Warranty

Unless otherwise specified, Starke guarantees that our products are free from material defects in design and workmanship under normal use, proper maintenance, and service.

This warranty is strictly limited to 12 months for single shift operation or 2,000 hours after installation, or 14 months after shipment, whichever is shorter. Within ten days after defect is found, warrantee must deliver a written notice to Starke providing defect information. All requested warranty information must be received promptly by Starke in no more than 5 business days.

Customer is responsible for all shipping charges on returned/warrantable items. Starke will cover the repair (parts and labor) at no charge or provide a replacement item at Starke's discretion.

This warranty does not cover defects or damage caused by acts of God, unusual wear and tear, improper use, or improper maintenance by the user. No responsibility for consequential damage is expressed or implied, and the responsibility under this warranty/guaranty is limited to the repair or replacement of the defective materials. Repair or replacement of the item is fully at the discretion of Starke.

ALL OTHER REPRESENTATIONS, EXPRESS OR IMPLIED, WARRANTY, OR LIABILITY RELATING TO THE CONDITION OR USE OF THE PRODUCT ARE SPECIFICALLY DISAVOWED, AND IN NO EVENT SHALL STARKE BE LIABLE TO BUYER, OR ANY THIRD PARTY, FOR ANY DIRECT OR INDIRECT CONSEQUENTIAL OR INCIDENTAL DAMAGES

STARKE

Starkeamerica.com/contact-us/

(Intentionally Left Blank)



Contact Your Starke Representative for More Information on Products to Help Maximize Your Workplace Efficiency



Hoists & Trolleys



Crane Components



Electrification



Crane Kits



Slings



Safety

