



OWNER'S MANUAL

# ElectroTrack Style Crane Kit

## Assembly Instruction Manual



# Table of Contents

1.0 Safety .....	3
2.0 Components List.....	4
3.0 Other Components .....	4
4.0 Installation Instructions .....	5
4.1 Tools Required .....	5
4.2 Installing End Trucks .....	6
4.3 Installing Your Starke ElectroTrack Brackets.....	7
4.3.1 Spacing Options.....	8
4.4 Paint .....	9
4.5 Panel Bracket Installation. ....	10
4.5.1 Panel Bracket Sizing.....	10
4.6 Installing ElectroTrack and Making Connections .....	11
4.6 Installing ElectroTrack and Making Connections (Continued) .....	12
4.6 Installing ElectroTrack and Making Connections (Continued) .....	13
4.7 End Truck Motor Installations .....	14
4.7.1 Geared End Truck Motor Installation (STT Model End Trucks).....	14
4.7.6 Geared End truck Motor Installation (SCU Model End Trucks).....	15
4.8 Installing the Wire Rope Hoist with Integrated Trolley.....	16
4.9 (Alternative) Installing Chain Hoist Trolleys .....	17
4.10 Installing Chain Hoists (Skip if Wire Rope Hoist is Used) .....	18
4.11 Fabricating and Installing the ElectroTrack Tow Bracket.....	19
4.12 Connecting Cables, Cable Management and Strobe Light Connection .....	20
4.12.2 Installing the Strobe Light .....	20
4.13 Installing End Stops .....	21
4.14 Installing Radio Receivers .....	22
4.15 Testing the Crane. ....	23
5.0 Troubleshooting .....	24
5.1 Diagnostics .....	24
6.0 Fastener Torque Specifications .....	25
7.0 Appendix A .....	26
7.1 Wiring Information .....	26
Starke Products Warranty .....	27

## 1.0 Safety

Safety comes first when assembling your Starke Crane Kit. For some items, proper tools and lifting equipment are necessary. Please be sure to select appropriate equipment to move or install heavy items. A forklift is highly recommended when installing – End-trucks, motors, the control panel, and the hoist/trolley.

To maximize efficiency, it is recommended that you install the electrical components and test the operation of the crane before installing the bridge. Doing so will reduce the risk of falling items, save time, and make testing faults easier. When setting up your work area, make sure the crane is set on stands that are built heavy enough to support the weight. Since it is necessary to access the bottom of the end-trucks, it is not recommended to support the crane from the end-trucks when installing components.

OSHA requires that you lock out and tag out the crane system before installation of another bridge crane, service/repairs, or any arial work performed around a crane system.

Listed below are the components included in your kit. You should also have a packing slip with the correct quantities of all items. Please verify that everything has arrived before beginning assembly.

## 2.0 Components List

- (1) Starke SCP control panel (warning strobe light shipped inside enclosure).
- (1) Starke control panel mounting bracket.
- (1) Control panel mounting hardware kit.
- (2) End trucks, bolt on style with plates (both left and right configurations).
- (2) End truck motor assemblies.
- (1) End truck bolt kit.
- (4) Rubber end-stop bumpers for end trucks.
- (2) Sets of clamp-on end stops. (Underhung hoists only).
- (1) Hoist and trolley assembly.
- (2) Motor lead sets, plug and play (one long & one short).
- (1) Power feed wire, plug and play connection to hardwire.
- (1) ElectroTrack kit (includes hangers, splice connectors, splice cover, power feed, end cap, collector, and tow arm).
- (1) Cable management kit.
- (1) Pillow block bearing and gear assembly. (SCU end trucks only).

## 3.0 Other Components

Due to the unique designs of each crane system, you will need to provide your own materials for these components:

- Tow bar mount to tow the Electro-Track Collector. (Tow Arm is included)
- Gear lubricant. (Grease gun required on SCT Model End Trucks)
- Paint
- Custom End-Stops. (Applies to Top Running Hoists Only)

## 4.0 Installation Instructions

### 4.1 Tools Required

- Torque wrench capable of 400 ft lbs.
- 9/16" combination wrench and socket wrench (with 1 ft extension).
- (2) 1/2" combination wrenches
- 3/4" combination wrench and socket wrench.
- 15/16" combination wrench and socket wrench.
- 3/8" combination wrench or socket wrench.
- 18mm combination wrench. (Qty. 2)
- 21mm combination wrench (for STT-250 End Trucks)
- 13mm combination wrench (for STT-170 End Trucks)
- 6mm Allen wrench (STT-250 End Trucks)
- #2 Philips screwdriver
- Precision screwdriver set
- 1 1/4" combination wrench and socket (Use with torque wrench).
- 1/4" Hex Impact driver. (8mm Socket Driver included in kit)
- 1/2" Drill and drill index including 1/4", 3/8" and 9/16" bit. (1/8" needed for SCT End Trucks)
- 1/2" impact wrench med/high torque and impact sockets up to 1 1/4" size.
- Welder
- Large framing square.
- Tape measure(s).
- Hammer(s).
- Misc electrical tools.
- Steel cutting tool (saw or grinder)
- Heavy duty saw horses, or similar items
- Forklift or overhead crane
- 10mm deep spcket and ratchet
- Needle nose pliers

Other tools and equipment may be used to make the assembly process faster.

## 4.2 Installing End Trucks

Tools Required: tape measure, framing square, large torque wrench with 1 ¼ socket, 1 ¼ combination wrench for STT style (15/16 for SCT), and a welder of your choice.

A 1/8" tolerance is required when aligning end trucks.

Use a framing square to achieve proper end-truck to girder alignment. After squaring Your end-trucks to your bridge girder, measure diagonally to confirm everything is square. If using the supplied plates, it is allowable to equally shim one side of the end-truck to achieve tolerance. DO NOT remove and reinstall bolts that have been previously torqued to spec. The bolts supplied are not meant to be re-used.

If using the supplied End-Truck plates, next torque down all end truck fasteners. (refer to torque specifications chart)



4.2.1 SCU Style End Truck



4.2.2 STT Style End Truck

### 4.3 Installing Your Starke ElectroTrack Brackets

Tools Required: 9/16" combination wrench, drill with 3/8" bit

Read these instructions first and then unpackage all the parts of your ElectroTrack kit. Get familiar with the different parts and be looking for the bolt-on ElectroTrack track runway hangers. The style of ElectroTrack brackets can vary with different systems. Optional C Channel brackets can be used for the bridge beam. Brackets are required when using S-beams.

The ElectroTrack should be placed on the side opposite the end truck motors and control panel.

**▲IMPORTANT NOTE:** In some cases, ElectroTrack hangers can be bolted directly to the I-Beam without using any type of runway brackets

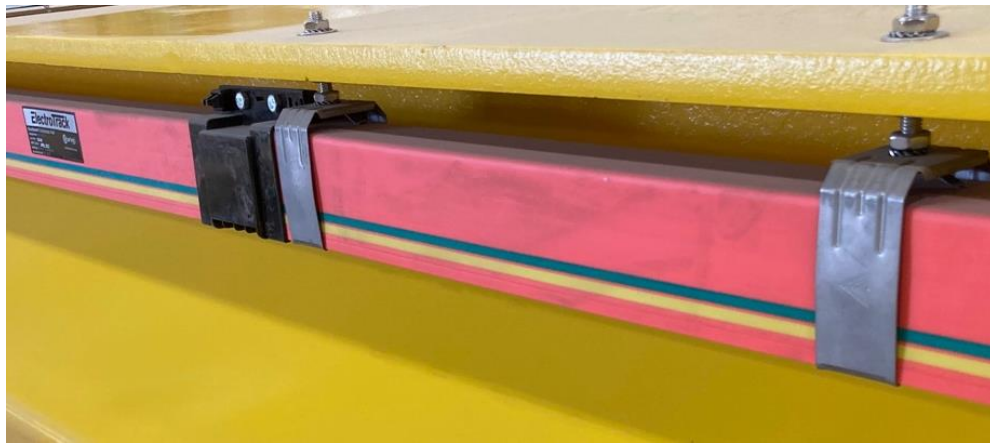

4.3.1 ElectroTrack Hanger Bolted Directly to Beam

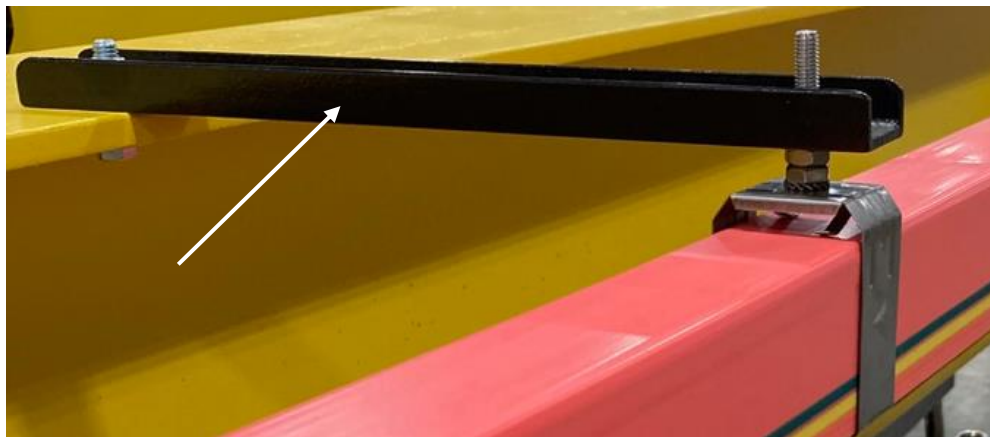

4.3.2 Channel Bracket Style

### 4.3.1 Spacing Options

Option A. (W beam with 4"+ flange)

Drill 3/8" holes into the top flange of your bridge girder every 79". It is recommended for the first hole to be drilled approximately 8 inches from the start of your bridge beam to accommodate for the Power feed box (shown below). It is recommended but not required that the holes are placed 1" from the edge of the beam flange.

Proceed to Step 3 before continuing.

Next bolt the ElectroTrack hangers directly to the beam.



4.3.2 ElectroTrack Hanger Bolted Directly to Beam

Option B. (Installing Brackets)

We recommend using 13 inch brackets to hang the electro-track hangers if you cannot fit the ElectroTrack under the top flange of the beam. Drill 3/8" holes into the top flange of your bridge girder every 79". It is recommended for the first hole to be drilled approximately 8 inches from the start of your bridge beam to accommodate for the Power feed box (shown below).

**▲IMPORTANT NOTE: You can weld the brackets on if you prefer.**

Proceed to Step 3 before continuing.

Next, bolt the ElectroTrack hangers to the brackets.



4.3.3 ElectroTrack Hanger Bolted to Brackets



#### 4.4 Paint

Tools Required: paint, and painting equipment.

When painting the crane, it is highly recommended to tape off a 1.5-2" section where the trolley wheels run. This will help the trolley roll smoother, and will keep paint scrape from building up, creating lumps for the wheels to drive over. With top running hoists, tape off the top of the rail.

It is also recommended to tape or plug the threaded holes where the end-truck motor mounts, to make installing the motor hardware easier.



4.4.1 Taped Off Section on Crane

## 4.5 Panel Bracket Installation.

Tools Required: drill with 9/16" bit, 3/4" wrench and socket wrench, 9/16" wrench and socket wrench, steel cutting tool.

**▲IMPORTANT NOTE: Use provided panel mounting hardware kit**

We recommend mounting the bracket on the right side of the crane (when facing the panel). Refer to the print below.

Determine the length of bracket needed for the control panel. A 3" clearance is recommended between the bracket and the hoist (see chart below for estimated minimum length requirements). Generally, with wire rope hoists leave the bracket full length, and install 2 inches onto the beam flange. With chain hoists, the bracket can be cut down to the correct length or left full length. If you are unsure about how much clearance you will have, you can mount the hoist and trolley first to determine the length of bracket needed. The location of the bracket is to be 5' from the center of the End Truck to center of the panel.

Drill two 9/16" holes in the beam flange to fasten the panel. It can either be fastened to the top of the top flange, or the bottom of the top flange. Use the provided hardware (1/2 grade 8 fasteners) to install the bracket. You can also install the panel at this point, using the 3/8x3.5" grade 5 bolts. Washers are necessary on the inside of the panel only

**▲IMPORTANT NOTE: When installing the panel bracket on the bottom of the top flange, a minimum of 2" of bracket on the beam flange is required.**

Type (Starke)	Capacity	Beam to Bracket Length
Chain Hoist	1/8 Ton to 1 Ton	13.5"
Chain Hoist	2 Ton to 5 Ton	14.5"
Wire Rope Hoist	3 Ton to 5 Ton	21.5"
Wire Rope Hoist	10 Ton	27.5"
Other	Any	Custom

4.5.1 Panel Bracket Sizing

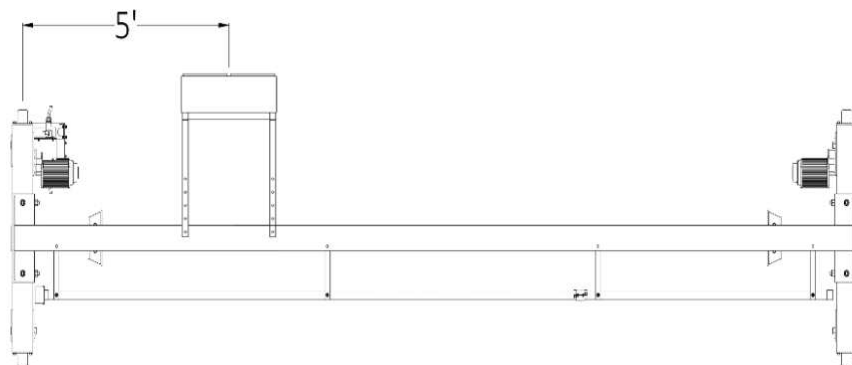
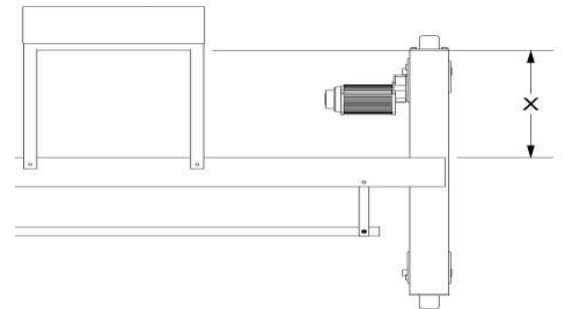

## 4.6 Installing ElectroTrack and Making Connections

Tools Required: needle nose pliers, 10mm deep socket with ratchet

At the end of the ElectroTrack system that will be closest to your bridge panel power supply, install one full length of the Starke ElectroTrack to be used for “incoming power”. (Green & Yellow color stripes should be facing away from the I-Beam.) Drill a ¼” hole in each copper conductor rail as shown below to connect incoming power wiring. At this point just drill the holes for the wires to connect to later.

Leave a 4-inch to 6-inch gap, then install the second section of ElectroTrack making sure the



4.6.1 End of ElectroTrack System



4.6.2 Gap Between ElectroTrack Systems

grounding conductor color stripes are lined up.

**▲IMPORTANT NOTE: Each orange track is marked with a yellow and green line. This line indicates where the ground conductor is located.**

Press a copper splice connector against the dimpled end of each of the 4 copper conductors as far as it will go.

**▲IMPORTANT NOTE: copper splice connector body goes to the outside of the copper conductor leaving a smooth transition on the inside face of the copper splice connector as shown below.**

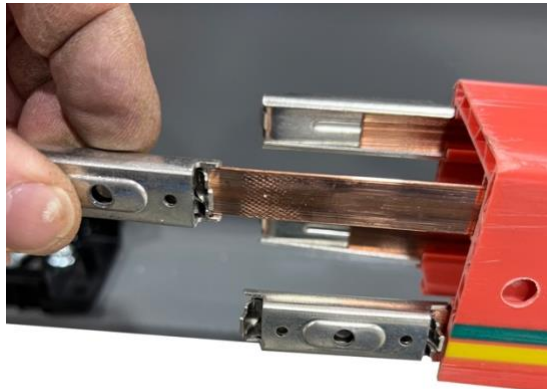

4.6.3 Adding the Copper Splice Connector

## 4.6 Installing ElectroTrack and Making Connections (Continued)

Push the next full track section of ElectroTrack copper conductors into the splice connectors installed previously. Once all 4 conductors are started into the corresponding copper splice connector, use a needle nose plier to work the conductors the rest of the way into the connectors fully. Copper conductor ends should preferably be in tight contact.



4.6.4 Copper Conductor Ends on Fully and in Tight Contact



4.6.5 Plastic Splice Cover Connecting Rails Together

Next, place one half of a plastic splice cover around the copper splice connectors and tight to the orange track. The pins on the cover should align with holes in the orange track. Press the other half of the plastic splice cover into place and pull the track housings together. Then bolt splice cover together. Repeat steps as necessary until the track is complete.



4.6.6 Rails Together



4.6.7 Splice Cover Pin

## 4.6 Installing ElectroTrack and Making Connections (Continued)

Place the End Power Feed housing on the “Incoming Power” end of the ElectroTrack. This will be the end closest to the panel. Next place a bolt through each copper conductor hole so that the bolt head is between the conductors.

Connect the supply wire to the conductors. Starting with grounding terminal, (green/yellow stripe) attach green wire then proceed with black, white, then red (red opposite to ground as shown below) Tighten the cord grip and tighten the connection nuts and bolts. Slide the End Power Feed cover in place and install the cover.



4.6.8 Bolt Head Between the Conductors

At the other end of the ElectroTrack install the 40 amp single collector. Make sure the grounding brush (yellow wire w/green stripe) is aligned with the ground terminal of the ElectroTrack. Next, push brushes in and slide collector into ElectroTrack. Depress the remaining brushes and slide 40 amp collector all the way in.

Finally, Install the ElectroTrack end cap on the end of the system.

**▲IMPORTANT NOTE: Tighten all hardware at this time.**



4.6.9 40 Amp Single Collector Installed



4.6.10 ElectroTrack End Cap Installed

## 4.7 End Truck Motor Installations

### 4.7.1 Geared End Truck Motor Installation (STT Model End Trucks)

Tools Required: 18mm combination wrench, (21mm for STT-250 end trucks) 13mm combination wrench (6mm Allen for STT-250 end-trucks), and grease.

For top running rail type end trucks, installing the geared motor on a 5 Ton to 10 Ton system will require the gear to be removed. Refer to the steps below. Do not fully bolt in the end truck motor before re-installing the gear. When you re-install the gear install the gear first, integrated collar facing the motor. Next install the spacing collar, followed by the washer and bolt assembly. Check to make sure the gears properly mesh. Use thread locker on the bolt/lock washer on the gear keeper bolt. Thread locker is provided in the cable management kit for your convenience. Verify that the gears mesh properly. Lubricate the gears using an open gear lubricant.

#### 4.7.2 Remove Gear



#### 4.7.3 Install Gear (Use Loctite)



#### 4.7.4 Install Hardware

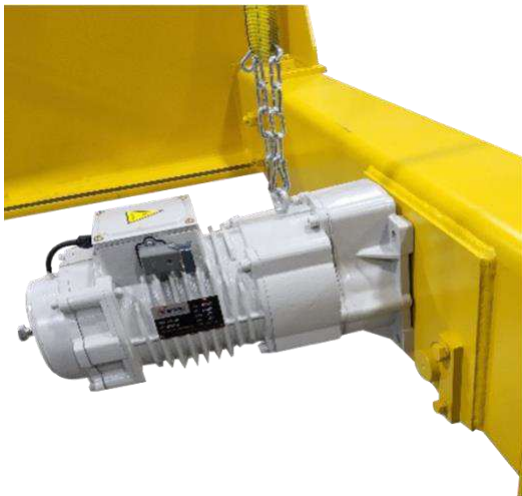

#### 4.7.5 Tighten Fasteners (See Torque Spec. Chart)

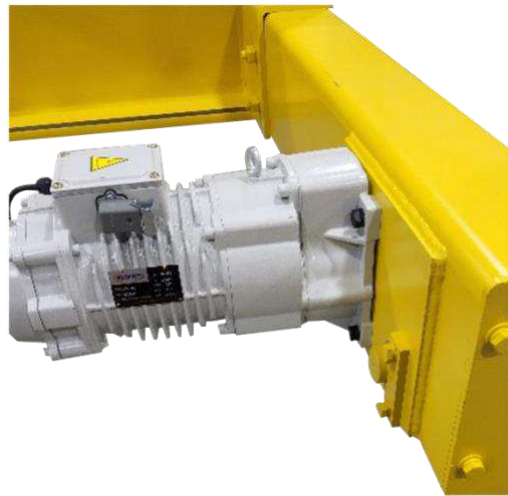

#### 4.7.6 Geared End truck Motor Installation (SCU Model End Trucks)

Install the geared motor and torque fasteners.

Next install the pillow block and gear assembly. Be sure to use the provided wedge washers on the angled part of the end truck, and regular washers on the pillow block itself. Before tightening, make sure gears mesh properly.

**▲IMPORTANT NOTE: Tightening without gears meshing may break the pillow block assembly. Do not overtighten. The pillow block may not be square to the end truck gear yet.**

Use the provided hex shaft as a lever to align the gears towards each other. Install the hex shaft. At this point, Check the gear lash. If the gears are tight, use the provided shims to loosen the gears. The gear should not be tight, there should be a small amount of gear lash.

**▲IMPORTANT NOTE: Gears being too tight will cause premature wear.**

After an acceptable lash is achieved, trim one end of the hex shaft to the proper length (1/2" longer than the gear assembly width) and reinstall the shaft. Next drill a 1/8 hole and install the keeper roll pin.

Lubricate the gears using an open gear lubricant, and pillow block bearing assembly using a grease gun.

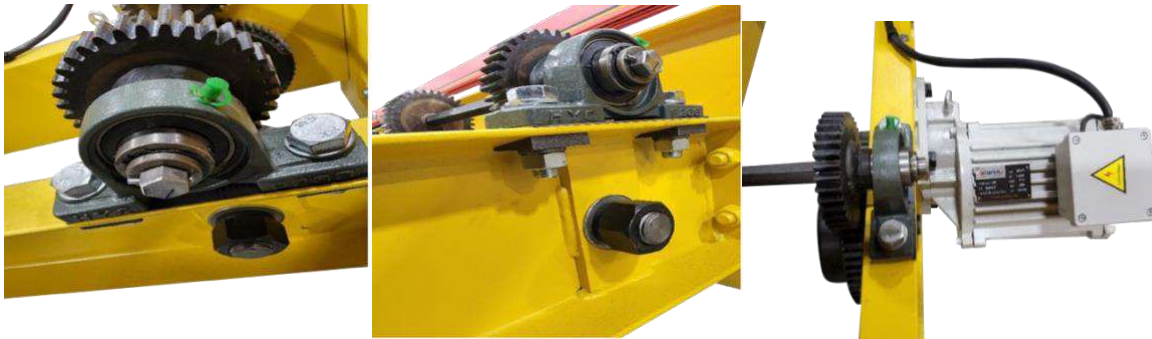

4.7.7 Gears

## 4.8 Installing the Wire Rope Hoist with Integrated Trolley

Tools Required: proper size wrench of your choice

**▲IMPORTANT NOTE: Does not apply to top running hoists.**

Begin by opening the trolley up wide enough to fit over the flange of the girder. To adjust the trolley size, first loosen the locking collar on the hex shaped wheel driveshaft (if equipped) then use the adjusting nuts to widen or narrow the trolley size.

**▲IMPORTANT NOTE: Adjust both nuts evenly to prevent binding!**

It can be helpful to grease the shaft that holds both sides of the hoist together. After adjusting the trolley to fit the beam, raise the trolley up to where the wheel height is above the bottom beam flange. Do not raise the hoist/trolley too high otherwise it will bind against the beam. This may cause binding issues! Use the adjusting nuts to draw the trolley back together onto the beam flange. The width of the trolley should be about 1/16 larger than the beam flange. To check this, after the trolley is set and the lifting platform/skit is removed, pull the hoist to one side, and measure/estimate the wheel to flange gap.

**▲IMPORTANT NOTE: It is imperative that the flange to wheel gap is the same on both sides. Failure to properly adjust wheel to flange gap will cause premature wheel wear.**

After the wheel to flange width is properly set, make sure to lock the driveshaft collar in place (if equipped) and tighten down all locking nuts.

**▲IMPORTANT NOTE: Failure to tighten all fasteners could result in injury or death.**

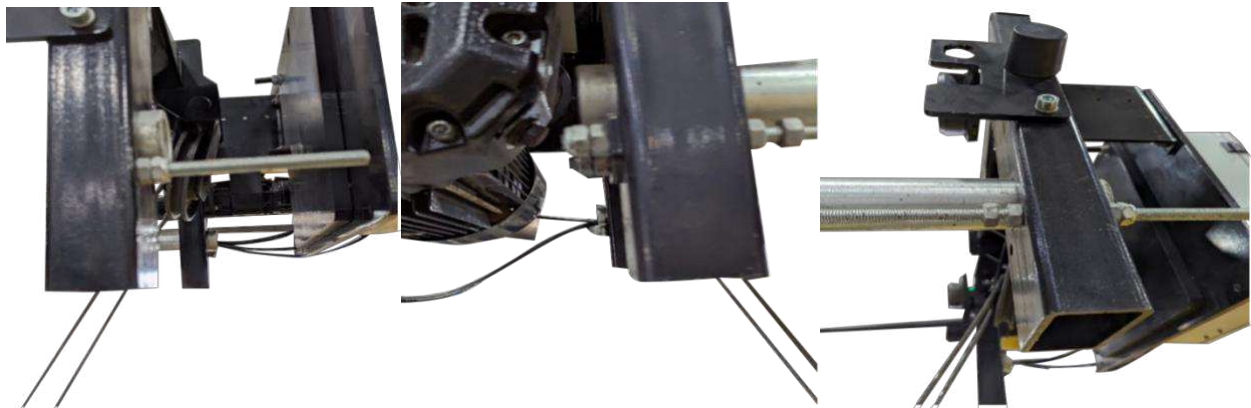

4.8.1 Fasteners on Driveshaft Collar



## 4.9 (Alternative) Installing Chain Hoist Trolleys

Tools Required: tape measure.

**▲IMPORTANT NOTE: installing the trolley before the crane is set is highly recommended**

First remove the pin holding the trolley together. Next, determine the spacing that your trolley is to be set at. The spacing should be  $1/16$ " to  $3/16$ " wider than your beam flange (measure from the side guide wheels on the trolley). Use the provided spacers to center the Hoist mounting lug in the center of the trolley. If the trolley cannot go wide enough for the flange, but is within one inch, remove the shaft bolt on the motor side, and move the shaft out one inch. If the trolley does not go wide enough even with the added spacing, contact your sales rep to order a "Trolley flange width adder".

**▲IMPORTANT NOTE: when installing a 5-ton trolley, make sure the secondary chain mount is facing the correct direction (right)**

Install the trolley onto the beam, panel end facing the festoon and double check spacing.

**▲IMPORTANT NOTE: failure to properly secure the cotter key could result in injury or death.**

Check for manufacturer defects when installing and bending the cotter key.

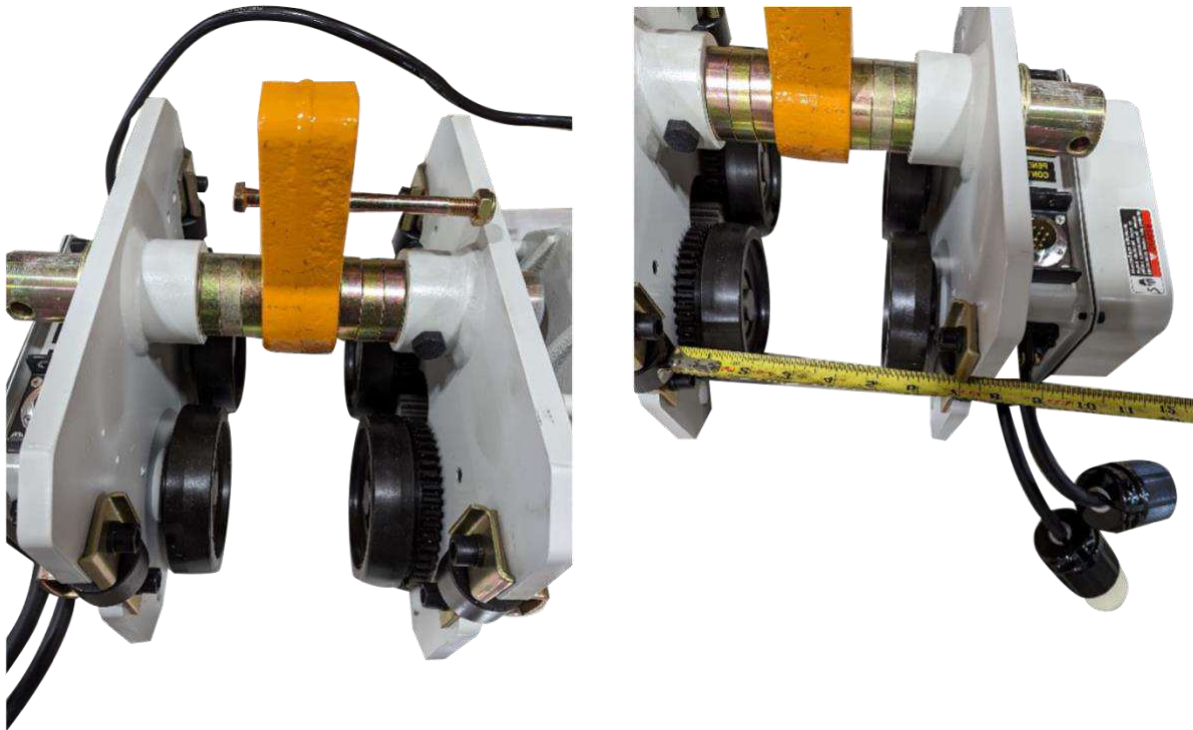

4.9.1 Spacing of Trolley

## 4.10 Installing Chain Hoists (Skip if Wire Rope Hoist is Used)

**▲IMPORTANT NOTE:** this step can be done after the bridge is installed

Tools Required: 18mm combination wrenches.

Remove the top pin from the hoist. Next hang the hoist, the panel side facing the festoon, and install the pin and cotter key. An anti-sway bolt is provided with the trolley to ensure minimal sway.

**▲IMPORTANT NOTE:** failure to properly secure the cotter key could result in injury or death.

**▲IMPORTANT NOTE:** check for manufacturer defects when installing and bending the cotter key.

Install the chain bag using the supplied hardware mounted on the hoist. You may have to pull the chain bag mounts into place to install.

Connect the patch cable to the hoist and tighten the retaining nut.

Connect the other end into the trolley (connect with hoist plug) and tighten the retaining nut. Next, connect the hoist power cord to the female power drop from the trolley.

After all cables are connected, you will need to fabricate, and install a festoon tow bracket to minimize drag on the festoon. This helps maximize the life of the festoon. (see page 18)



4.10.1 Hoist Plug



4.10.2 Chain Bag

## 4.11 Fabricating and Installing the ElectroTrack Tow Bracket

Tools Required: ½" combination wrenches

Due to differing beam sizes and widths, you will need to fabricate a custom Electrotrack tow bracket. Attach the silver tow arm to your custom bracket. Please make sure the fingers stick past the collector to prevent the collector from slipping out of the tow bracket. Pictured below is an example of the tow arm on a custom bracket that we used.



4.11.1 Tow Arm Bracket

## 4.12 Connecting Cables, Cable Management and Strobe Light Connection

Tools required: drill with 1/4" bit, #2 Phillips, 3/8" combination wrench.

Install the cables for the end trucks. It does not matter which cable goes to panel plug A or panel plug B at this time. We recommend mounting the cables on top of the crane and using the adhesive tie mounts to secure them down. Adhesive tie mounts and zip ties are found in your cable management kit.

**▲IMPORTANT NOTE:** when installing adhesive tie mounts, clean the surface that you are placing the pad on first, then install the pads.



4.12.1 Cable Management

### 4.12.2 Installing the Strobe Light

After all cables are installed, install the strobe light into the bottom of the panel. Inside the panel there is a power plug that will connect to the strobe light. The strobe light will only flash when the bridge is in motion.

## 4.13 Installing End Stops

Tools required: 15/16 combination wrenches.

Refer to the photos below for proper installation of end stops.

It is recommended to cut the threaded rod to the width of your crane. End stops should be placed so that you have a minimum distance of 3 inches between the hoist/trolley and any other item that it could hit.

**▲IMPORTANT NOTE: The stack up of festoon can also affect the end stop placement. Do not place the end-stop too close to the end-truck to where the festoon pulls too tight.**

Tighten the end stop bolts first, then tighten the threaded rod. This will ensure that the end stop stays straight and has maximum contact on the beam. After everything is hand tight, torque to spec.

**▲IMPORTANT NOTE: Top Running Hoists do not come with this type of end-stop. You will need to fabricate your own end stops for this type of hoist.**



### 4.13.1 End Stops

## 4.14 Installing Radio Receivers

The last step to building your crane kit is installing the radio receivers

First install the radio receiver onto the main control panel. Use the provided spring to mount the receiver, then plug the receiver into the 16 pin plug.



4.14.1 Radio Receiver Installed on Control Panel

Then install the second receiver onto the hoist using the spring provided, then plug the receiver into the 18 pin plug on the hoist panel.

**▲IMPORTANT NOTE:** Depending on the type of hoist, the Radio Receiver may already come pre-attached



4.14.2 Radio Receiver Pre-Attached on Control Panel

An initial press of the start button starts the radio receiver on the bridge panel. After the radio receiver has started, the panel is now supplying power to the radio on the hoist. The radio receiver on the hoist must then be started by pressing the start button again.

## 4.15 Testing the Crane.

Tools required: miscellaneous electrical tools.

**▲IMPORTANT NOTE: to ensure everyone's safety, testing is to be done by a qualified electrician. It is recommended that you test the crane before installing onto your runway.**

After all plugs are connected, Install the power wire, and connect to your building power.

All crane systems are required to have a safety disconnect clearly marked to ensure easy shut-down in case of emergency.

**▲IMPORTANT NOTE: due to the crane being controlled using a Variable Frequency Drive, it can be tested, but generally will not run well on generator power.**

Due to the Unique design of the ElectroTrack system, the startup sequence will be a bit different than festoon. To start your crane, first press the start button, wait 2 seconds then press that start button again.

Once you have the correct power connected to your crane, you can begin testing. If the bridge runs backwards, swap the motor plugs (a and b) on the control panel. If the trolley moves backwards, you will need to swap the two red wires on the relays mounted on the panel door labeled T FWD and T REV. If the hoist (can be tested later if installing with the crane set on the runways) does not move up and down, or makes a clicking sound while not running, swap the hoist power plug wires (black and red) or the main incoming power phases.

**▲IMPORTANT NOTE: Swapping the main input phases will not affect bridge or trolley motion. If there are other issues present, contact your dealer for technical support.**

After the crane is tested, double check that all bearings, and gears that can be greased, have been greased. It is important that you check all hoisting components for proper lubrication. Refer to the component's manual specifications for additional details.

For Grounded B phase systems, the grounded phase must be line 2 (white) double check that the grounded leg is not on the control transformer input power. If the grounded phase is on lines 1, or 3, the control transformer will not supply the proper control power, and the control circuit will not run.

## 5.0 Troubleshooting

### 5.1 Diagnostics

Relays in panel click but end truck motors don't run.

Check to make sure the drive displays a frequency number, if not.

- LCP is on off/reset
- Drive isn't programmed (call customer support)
- Lost control to drive. Check control wires(on drive connections, test DC between #20 and the 3 inputs (18,19,27))

Drive displays a frequency number, but crane doesn't move

- Check input power
- Check power to the drive
- Make sure brake contactor pulls in when a motion button is pressed

Motors not in sync

- Make sure all wires are tight from drive to motor connections
- Check braking system, can you hear each end truck brake "click"
- Ohm motor connections\*\*\*\*\*
- Last option on new cranes only! Check center to center of end trucks.

Motors run in opposite directions

- Contact your dealer for help regarding switching motor phasing

Relays in panel don't turn on at all

- Check radio or pendant connections
- Test power to relays and find where signal power is lost (check between top terminal #1 and input power to the terminal strips, then directly on the signal coil on the relays)

Crane won't turn on at all

- Check control fuse (light on holder should illuminate if the fuse is blown)
- Check for a green light on the radio, if no light check power between x1 and x2 (see schematics)
  - If no power is found, check input power to transformer and output power before the fuse. CHECK FOR GROUNDED B PHASE BEFORE REPLACING TRANSFORMER
- If radio functions check for power between x2 and MLC terminal, followed by checking power directly on main line contactor signal (A1 & A2)

Hoist Clicks or doesn't run

- Swap phasing on the hoist.
- Make sure all plugs are connected.
- Make sure limit switch is not stuck
- Test power at hoist plug. (Refer to appendix A)



## 6.0 Fastener Torque Specifications

Bolt type	Torque spec.
M6 8.8 (gear retainer)	84 IN/LB (10.5 NM)
M12 8.8 (motor mount)	75 FT/LB (101 NM)
M16 10.9 (Pillow Block)	55 FT/LB (27 NM) over torque can break bearing mounts
10-32 GR2 (footman loop)	31 IN/LB (hand tight)
3/8 GR5 (panel mount)	36 FT/LB (49 NM)
1/2 GR8 (panel bracket)	Up to 120 FT/LB (162 NM)
5/8 GR5	170 FT/LB (230 NM)
3/4 A325 (End trucks)	Dry 350 to 425 FT/LB Oiled 260 to 320 FT/LB

## 7.0 Appendix A

### 7.1 Wiring Information

#### Plug Pin-Out

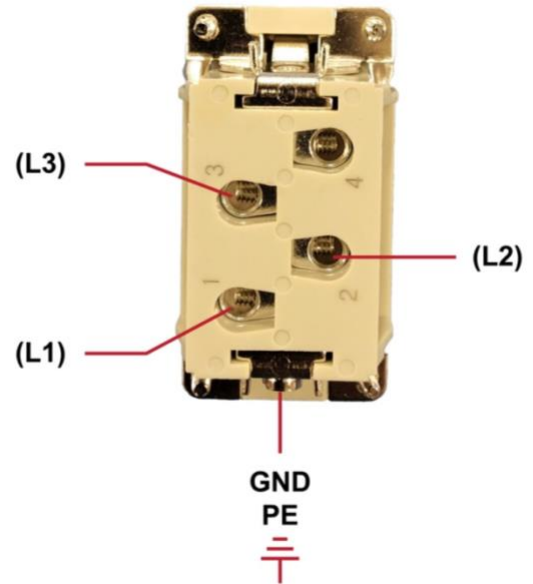
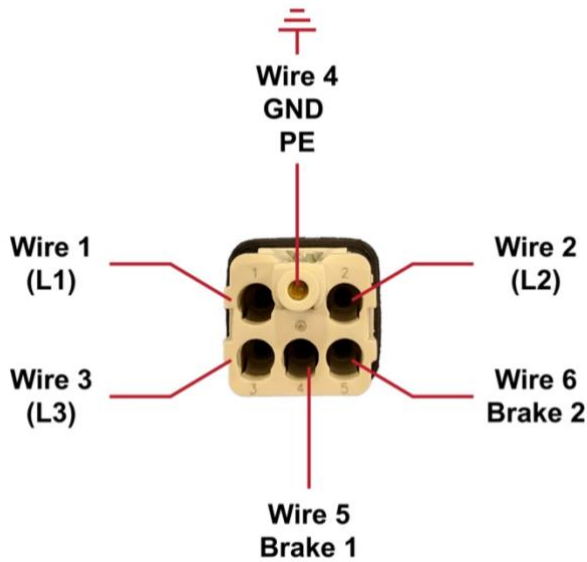
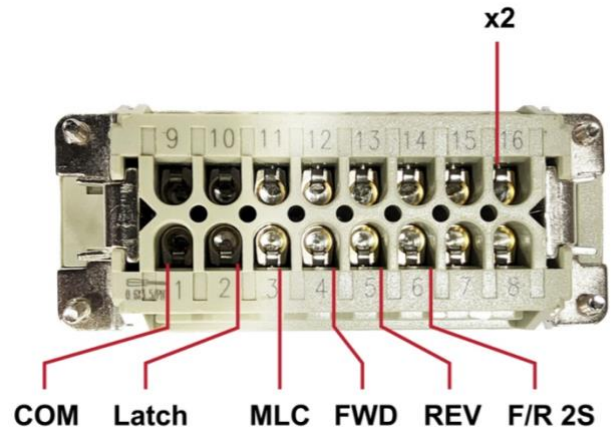
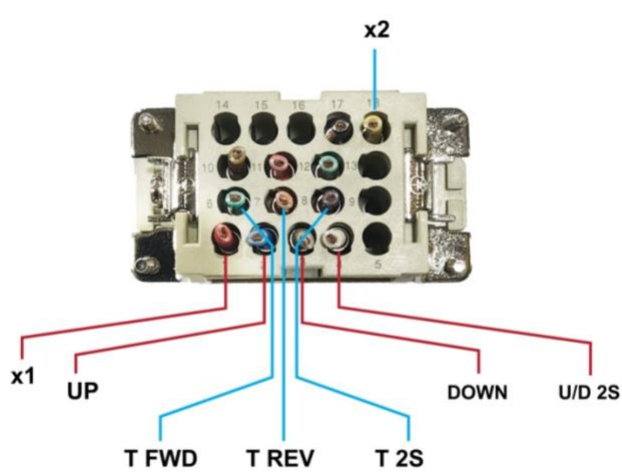

Other manuals are available for Starke products on the [Starkeamerica.com](http://Starkeamerica.com) website.



---

## **Starke Products Warranty 1 Year (12 Month) Parts & Labor Warranty**

Unless otherwise specified, Starke guarantees that our products are free from material defects in design and workmanship under normal use, proper maintenance, and service.

This warranty is strictly limited to 12 months for single shift operation or 2,000 hours after installation, or 14 months after shipment, whichever is shorter. Within ten days after defect is found, warrantee must deliver a written notice to Starke providing defect information. All requested warranty information must be received promptly by Starke in no more than 5 business days.

**Customer is responsible for all shipping charges on returned/warrantable items. Starke will cover the repair (parts and labor) at no charge or provide a replacement item at Starke's discretion.**

This warranty does not cover defects or damage caused by acts of God, unusual wear and tear, improper use, or improper maintenance by the user. No responsibility for consequential damage is expressed or implied, and the responsibility under this warranty/guaranty is limited to the repair or replacement of the defective materials. Repair or replacement of the item is fully at the discretion of Starke.

*ALL OTHER REPRESENTATIONS, EXPRESS OR IMPLIED, WARRANTY, OR LIABILITY RELATING TO THE CONDITION OR USE OF THE PRODUCT ARE SPECIFICALLY DISAVOWED, AND IN NO EVENT SHALL STARKE BE LIABLE TO BUYER, OR ANY THIRD PARTY, FOR ANY DIRECT OR INDIRECT CONSEQUENTIAL OR INCIDENTAL DAMAGES*

STARKE

[Starkeamerica.com/contact-us/](http://Starkeamerica.com/contact-us/)







**(Intentionally Left Blank)**



Contact Your Starke Representative for More Information on Products to Help Maximize Your Workplace Efficiency



**Hoists & Trolleys**



**Crane Components**



**Electrification**



**Crane Kits**



**Slings**



**Safety**

