



Cantilever Jib Crane Systems

Installation, Operation, & Maintenance Manual



OWNERS RECORDS

Date purchased _____

Serial Number _____

Order Number _____

TABLE OF CONTENTS

Installation Safety	4
Pre-Installation Checklist & Capacity info	5
Pre-assembly & Installation	6
Installation of Electrification	7
Crane Operator Basic Instructions	8
General Safety & Daily Inspection	9
Parts Dept & Drawings Available	11
Warranty	12
Periodic Inspections	14

Before you begin. Read the instructions carefully, from beginning to end, and follow the proper sequence. On the next page you'll find a safety section and general checklist that you should read before starting your installation.

Thank you for purchasing a PWI crane system! We have been building overhead cranes for years and our experience and knowledge should give you peace of mind. We too use overhead cranes in our manufacturing processes. From design & engineering, all the way to installation of our crane systems, our experience and passion for quality crane systems is shown in our products. We hope you find the installation ease and use of our PWI products to be among the best items you have purchased.

Thank you from the entire staff at PWI.

PWI
7930 W 1000 N
Nappanee IN 46550

pwiworks.com
Phone: 574-646-2015
Email: sales@pwiworks.com

General Safety

Safety comes first when unloading and assembling your jib crane system. Many of the components are heavy and require lifting tools to move and set them in place. Make sure the equipment you choose to support and lift each piece is capable of the task with extra capacity to do the job. Do not end up in a dangerous situation.

Start with checking any lifting fixtures/tools for damage or wear that could lead to severe injury or death.

This manual assumes that you have performed any foundation work ahead of placing your crane system in the proper location. Failure to provide the proper footing depth and width based on your column loads can result in failure of the floor structure supporting your crane. Please call PWI if you are unsure of the requirements for your PWI Crane System.

WARNING

There must be 3" minimum clearance above the horizontal beam to any obstruction.

Pre-Installation Checklist:

- Check your shipment for the correct components and hardware. Your shipment should include shipping sheets that were checked off by our team
- Check your shipment for drawings for layout and installation of components
- Clear the area as much as possible of items that could be damaged or create hazards during the installation. When assembling near electrical panels be aware of any regulations regarding perimeters required around those objects
- Forklift or suitable lifting equipment
- Should you have any technical questions, or feel you have defective components or missing items, call us immediately. We will be glad to assist you.

Tools

- Markers, Tape Measures, Chalk Line, and Square
- Ladders/Man Lifts
- Hammer, Prybar, Clamps, and Line Up Punches
- Torque Wrench, Hand Wrenches, and Socket Set
- Leveling Tools (Level, Water Level, Laser Level)
- Lifting Equipment

System Capacity Information

The heavy-duty construction of the PWI Jib Crane will provide a superior quality product that will offer years of long-term value. The hoist weight allowance is 15% of the cranes capacity (for example, a crane rated for 6000 pounds allows for a 6000-pound live load plus 900 pounds for the weight of the hoist). There is also an allowance of 15% of the crane capacity for impact caused by hoist use.

Step 1. Jib Crane Installation

1.1 Your PWI Jib Crane is partially assembled when shipped. Assembly of the beams will require bolting the hinge to the Jib frame. Install the Hinges as shown and then install the Jib Beam.

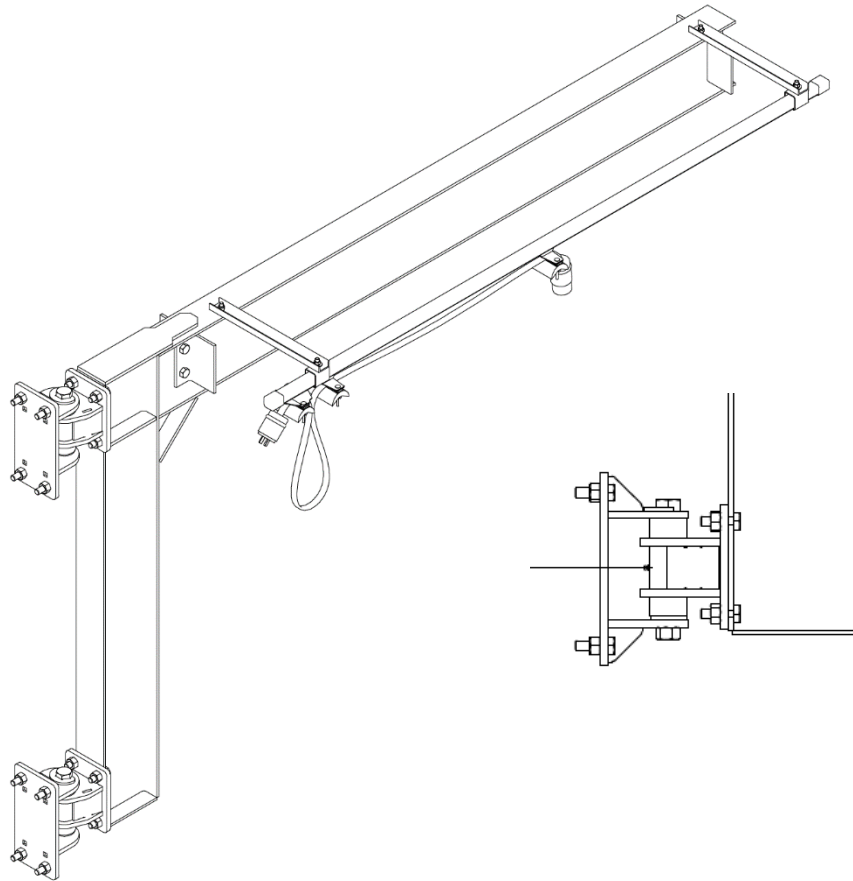

1.2 Drill holes as needed in your structure and then bolt hinges.

1.3 Remove outer Jib I-beam **end stop kit** from end of horizontal I-Beam and roll trolley onto the Jib beam.

1.4 Re-install the end stop kit and verify hardware of both sets of end stops are tight.

Step 2. Hoist Electrification Installation on Your Jib

Standard electrification for the Jib beam is 4 conductor festoon wire.

2.1 Install the **hoist** trolley onto the beam. (Step 1.3)

2.2 Holding a festoon trolley in your hand, loosen the wire clamp plate nuts on the festoon trolleys and then roll trolleys into festoon track.

2.3 Next, on the end of the **festoon track** that is closest to the **power source**, install the clamp type festoon wire hanger at that end of the track. (Image 2A)

2.4 Install festoon wires through festoon trolleys and festoon clamp. Making sure to have enough wire to make the connection to the building power, tighten festoon clamp. Position the rolling festoon trolleys every 60" along the **festoon wire** and tighten clamp plates. Be sure not to over tighten as this could damage the festoon wire.

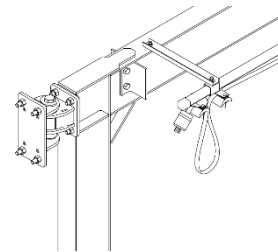

Image 2A. Wire Clamp.

➡ **TIP:** Do not throw away this manual: the maintenance schedule is included. Keep Packing List, Installation Manual, General Arrangement Drawing, and any other inserts filed together in a safe place.

CRANE OPERATOR INSTRUCTIONS

PWI Overhead cranes and jib cranes generally handle materials over working areas where there are personnel. Therefore, it is important for the Crane Operator to be instructed in the use of the crane and to understand the severe consequences of careless operation.

It is not intended that these suggestions take precedence over existing plant safety rules and regulations or OSHA regulations. However, a thorough study of the following information should provide a better understanding of safe operation and afford a greater margin of safety for people and machinery on the plant floor. It must be recognized that these are suggestions for the Crane Operator's use. It is the responsibility of the owner to make personnel aware of all federal, state, and local rules and codes, and to make certain operators are properly trained.

Qualifications

Crane operation, to be safe and efficient, requires skill: the exercise of extreme care and good judgement, alertness and concentration, and rigid adherence to proven safety rules and practices as outlined in applicable and current ANSI and OSHA safety standards. In general practice, no person should be permitted to operate a crane:

- Who cannot speak the appropriate language or read and understand the printed instructions.
- Who is not of legal age to operate this type of equipment.
- Whose hearing or eyesight is impaired (unless suitably corrected with good depth perception).
- Who may be suffering from heart or other ailments which might interfere with the operator's safe performance.
- Unless the operator has carefully read and studied this operation manual.
- Unless the operator has been properly instructed.
- Unless the operator has demonstrated his instructions through practical operation.
- Unless the operator is familiar with hitching equipment and safe hitching equipment practices.

Handling the Trolley Motion

Before a load is handled, the hoist should be positioned directly over the load that is to be handled. When the slack is taken out of the slings, if the hoist is not directly over the load, bring it directly over the load before hoisting is continued. Failure to center the

hoist over the load may cause the load to swing upon lifting. Always start the trolley motion slowly and reduce the trolley speed gradually.

Handling the Hoist Motion

Refer to the lifting (hoist) equipment's operating instructions.

GENERAL SAFETY SUGGESTIONS

Know Your Crane

Crane operators should be familiar with the principal parts of a crane and have a thorough knowledge of crane control functions and movements. The crane operator should be required to know the location and proper operation of the main conductor disconnecting means for all power to the attachments on the crane.

Responsibility

Each crane operator should be held directly responsible for the safe operation of the crane. Whenever there is any doubt as to SAFETY, the crane operator should stop the crane and refuse to handle loads until: (1) safety has been assured or (2) the operator has been ordered to proceed by the supervisor, who then assumes all responsibility for the SAFETY of the lift.

Do not permit **ANYONE** to ride on the hook or a load.

Daily Inspection

Test the crane movement and any attachments on the crane at the beginning of each shift. Whenever the operator finds anything wrong or apparently wrong, the problem should be reported immediately to the proper supervisor and appropriate corrective action taken.

Operating Suggestions

One measure of a good crane operator is the smoothness of the crane operation. The good crane operator should know and follow these proven suggestions for safe, efficient crane handling.

1. The jib crane should be moved smoothly and gradually to avoid abrupt, jerky movements of the load. Slack must be removed from the sling and hoisting ropes before the load is lifted.
2. Center the crane over the load before starting the hoist to avoid swinging the load as the lift is started. Loads should not be swung by the crane to reach areas not under the crane.

3. Crane-hoisting ropes/chains should be kept vertical. Cranes shall not be used for side pulls.
4. Be sure everyone in the immediate area is clear of the load and aware that a load is being moved.
5. Do not make lifts beyond the rated load capacity of the crane, sling chains, rope slings, etc.
6. Make certain that before moving the load, load slings, load chains, or other lifting devices are fully seated in the saddle of the hook with hook latch closed (if equipped with hook latch).
7. Check to be sure that the load and/or bottom block is lifted high enough to clear all obstructions when moving boom or trolley.
8. At no time should a load be left suspended from the crane unless the operator has the push button with the power on, and under this condition keep the load as close as possible to the floor to minimize the possibility of an injury if the load should drop. When the crane is holding a load, the crane operator should remain at the push button.
9. Do not lift loads with sling hooks hanging loose. If all sling hooks are not needed, they should be properly stored, or use a different sling.
10. All slings or cables should be removed from the crane hooks when not in use (dangling cables or hooks hung in sling rings can inadvertently snag other objects when the crane is moving).
11. Operators shall not carry loads and/or empty bottom blocks over personnel. Caution should be practiced when using magnet or vacuum devices. Loads, or parts of loads, held magnetically could drop. Failure of power to magnets or vacuum devices can result in dropping the load. Extra precaution should be exercised when handling molten metal in the proximity of personnel.
12. Whenever the operator leaves the crane, the following procedure should be followed:
 - Raise all hooks to an intermediate position.
 - Spot the crane at an approved designated location.
 - Place all controls in the "off" position.
 - Open the main switch to the "off" position.
 - Make visual check before leaving the crane.
13. In case of emergency or during inspection, repairing, cleaning or lubrication, a warning sign or signal should be displayed, and the main switch should be locked in the "off" position. This should be done whether the work is being done by the crane operator or by others.
14. Contact with rotation stops or trolley end stops shall be made with extreme caution. The operator should do so with particular care for the safety of persons below the

crane, and only after making certain that any persons on the other cranes are aware of what is being done.

ANY SAFETY FEATURES AND MECHANISMS BUILT IN OR OTHERWISE PROVIDED WITH THE CRANE BY PWI ARE REQUIRED FOR THE SAFE OPERATION OF THE CRANE. DO NOT, UNDER ANY CIRCUMSTANCES, REMOVE OR OTHERWISE IMPAIR OR DISABLE THE PROPER FUNCTIONING OF ANY CRANE SAFETY MECHANISMS OR FEATURES BUILT-IN OR OTHERWISE PROVIDED BY PWI FOR SAFE OPERATION OF THE CRANE. ANY REMOVAL, IMPAIRMENT OR DISABLING OF ANY SUCH SAFETY MECHANISMS OR FEATURES OR OTHER USE OR OPERATION OF THE CRANE WITHOUT THE COMPLETE AND PROPER FUNCTIONING OF ANY SUCH SAFETY MECHANISMS OR FEATURES AUTOMATICALLY AND IMMEDIATELY VOIDS ANY AND ALL EXPRESS AND IMPLIED WARRANTIES OF ANY KIND OR NATURE.

Parts- Your system is custom designed for your space. The drawings that you received are specific to your system. PWI has copies of your drawings in a file under the company name or the name of the purchaser. If you require replacement parts, please call or email PWI and we will be glad to assist you in getting what you need.

574-646-2015

parts@pwiworks.com



LIMITED WARRANTY

STRUCTURAL: 3-Year (36 Month) Parts & Workmanship Warranty

Structural items include but are not limited to columns, headers, runways, and other stationary components of this PWI Ultra Lite System.

Unless otherwise specified, PWI guarantees that the structure or this product is free from material defects in design, materials, and workmanship under normal use, proper maintenance, and service. A corrosive or abrasive atmosphere is not to be considered a normal atmosphere.

This warranty is strictly limited to 36 months for single shift operation or 6,000 hours after installation, or 38 months after shipment, whichever is shorter. Within ten days after defect is found, warrantee must deliver a written notice to PWI. All requested warranty information must be received promptly by PWI in no more than 5 business days.

MECHANICAL: 1 Year (12 Month) Parts & Workmanship Warranty

Mechanical items include but are not limited to all types of Overhead Cranes, and other non-stationary PWI products that are designed for specific functional operation.

Unless otherwise specified, PWI guarantees that this mechanical product is free from material defects in design and workmanship under normal use, proper maintenance, and service.

This warranty is strictly limited to 12 months for single shift operation or 2,000 hours after installation, or 14 months after shipment, whichever is shorter. Within ten days after defect is found, warrantee must deliver a written notice to PWI. All requested warranty information must be received promptly by PWI in no more than 5 business days.

All standard non-engineered products including but not limited to hoists, trolleys, wheels, gearmotors, controls, and safety products, will fall under the default warranty of that specific manufacturer.

GENERAL:

This warranty will not apply to any product that has been repaired or altered outside of PWI manufacturing plant, or without specific instructions from PWI to make alterations. PWI will in no case, allow or offer reimbursement for outside sources to perform repairs or make alterations to product in reference. If the product has (in PWI's judgment), had alterations made which adversely affect its serviceability or was subject to misuse, negligence, accident, or operated contrary to instructions or common practice, warranty shall be considered void.

Defective items will be repaired or replaced and returned to PWI at the cost of the owner. If PWI, at its discretion, finds the warranty claims to be justifiable, PWI will compensate by means of replacing or repairing faulty products or components free of charge. The sole liability of PWI for warranty claims is limited to those here. In no event will PWI be liable for damages in excess of the original sale price of the defective product, or for any consequential damages, nor will PWI be liable for any special or other work done unless specifically agreed to in writing. This warranty does not include or apply to fire, natural disasters, or other Acts of God.

Should the warrantee destroy, intentionally or not, any part of the warranted product, or any evidence concerning the origin of an alleged defect, or try to conceal evidence of causation, this warranty is cancelled, and warrantee will have no claim against PWI whatsoever.

This warranty does not cover coatings on any PWI products including paint, powder-coat, zinc, or galvanized coatings. Coating life can vary greatly based on the ambient environment your PWI product is installed in, which is simply out of the manufacturer's control. Touch-up painting or coating repair (after initial installation by PWI or customer) shall be the responsibility of the owner, unless specifically guaranteed in writing on project quotation.

Any interpretation of this warranty shall be done in common pleas court in Indianapolis under Indiana law.

ALL OTHER REPRESENTATIONS, EXPRESS OR IMPLIED, WARRANTY, OR LIABILITY RELATING TO THE CONDITION OR USE OF THE PRODUCT ARE SPECIFICALLY, DISAVOWED, AND IN NO EVENT SHALL PWI BE LIABLE TO BUYER, OR ANY THIRD PARTY, FOR ANY DIRECT OR INDIRECT CONSEQUENTIAL OR INCIDENTAL DAMAGES

PERIODIC INSPECTION AND LUBRICATION RECOMMENDATIONS

The following is a checklist to be followed in performing periodic inspections and preventative maintenance on PWI Crane Systems. It is intended that this checklist be supplemented with any additional instruction sheets and maintenance manuals sent with each job.

The frequency of inspection and lubrication recommendations presented herein is based upon normal operating conditions of one complete handling cycle every 10 minutes throughout a 40-hour week. If the actual duty cycle of a particular unit is greater or less than this, the inspections and lubrications should be performed more frequently or less frequently in proportion.

Each industry has conditions peculiar to it, which may cause wear of certain parts. The tabulation given is only general and may be supplemented by an individual maintenance department program to meet its own particular requirements. Particular attention should be given to corrosive conditions, excessive vibrations, extreme ambient temperature variations, and rough handling conditions.

Questions regarding damaged, worn or cracked equipment components should be directed to the PWI Inside Sales Department at 574-646-2015.

The recommendations contained herein are to be supplemented by any vendor instructions, which are included in this manual.

WARNING: Power should be off and locked when performing maintenance on any part of the system.

* State and local codes may require inspection and maintenance checks more often. Please check the state and local code manuals in your area.

RUNWAYS & SUPPORT STEEL

Item	Component	Maintenance	Frequency
1	Column Anchoring	Check for loose bolts & cracks in surface	Every 6 Months
2	Joints	Check for loose or worn hardware or cracks in structure	Yearly
3	End Stops	Check for loose bolts and/or cracks in beam or stops	Yearly
4	Hinges	Check for worn parts, cracks and/or loose hardware	Yearly
5	Paint	Clean periodically and repaint if corrosion is present	Yearly
6	Electrification	Look for cuts, tears in wiring. Inspect all trolleys and connections	Every 6 Months

HOIST (Refer to Hoist Manufacturer)

Notes
